

JLX[®]

330' Laser Distance Meter w/Angle Sensor and Bluetooth[®] Model No. LDM330



Instruction Manual

Congratulations on your choice of this JLX[®] branded Laser Distance Meter from Johnson. JLX[®] tools represent the highest quality tools Johnson has to offer, designed for professional users looking to work smarter, faster and more efficiently. This Bluetooth[®] equipped LDM also features an integrated angle sensor for simplifying complex measurements and functions as a pocket-sized digital level. We suggest you read this instruction manual thoroughly before using the instrument and save this instruction manual for future use.

This is a Class II laser tool and is manufactured to comply with CRF 21, parts 1040.10 and 1040.11 as well as international safety rule IEC 285. The laser also complies with EMC Test according to EN61000-6-3; 2001+A11:2004, EN 6100-6-1:2011, EN 6100-4-2, EN 61000-4-3, EN 60825, FCC Test according to PART 15.



Table of Contents

- | | |
|--|------------------------------|
| 1. Kit Contents | 8. Using the Bluetooth® App |
| 2. Features and Functions | 9. Tips from the Pros |
| 3. Safety Instructions | 10. Care and Handling |
| 4. Location/Content
of Warning Labels | 11. Troubleshooting Guide |
| 5. Location of Parts/Components | 12. Technical Specifications |
| 6. Battery Installation | 13. Product Warranty |
| 7. Operating Instructions | 14. Warranty Registration |
| | 15. Accessories |

1. Kit Contents

Description

Qty.

Laser Distance Meter	1
“AAA” Alkaline Batteries	2
Wrist Strap	1
Soft-Sided Pouch	1
Quick Start Guide	1





2. Features and Functions

- Nine (9) measurement modes: Length (Single or Continuous), Area/Square, Volume/Cube, 1-Point Pythagoras, 2-Point Pythagoras, 3-Point Pythagoras, 3-Point Partial Pythagoras, Digital Level and Stake-out (English units only)
- Displays in English or metric units with decimals or fractions (English units only)
- ISO 16331-1 tested* to typical accuracy of +/- 1/16" (0.0625", or 1.5mm)
- Bluetooth® enabled for syncing with the Johnson Measure-Up™ app (iOS or Android)
- High-speed microprocessor for quick, accurate calculations
- IP 54 protection – sealed from dust and rainwater

* This tool is tested in accordance with ISO 16331-1 "Laboratory procedures for testing surveying and construction instruments – Part 1: Performance of handheld laser distance meters." This standard is used to calculate accuracy under varying ambient lighting conditions. For more detailed test results, see the Technical Specifications section of this operator's manual.





3. Safety Instructions

Please read and understand all of the following instructions, prior to using this tool. Failure to do so, may void the warranty.

DANGER!

Class II Laser Product
Max. Power Output: $\leq 1\text{mW}$
Wavelength: 650nm

**THIS TOOL EMITS LASER RADIATION.
DO NOT STARE INTO BEAM.
AVOID DIRECT EYE EXPOSURE.**



ATTENTION



IMPORTANT

- Read all instructions prior to operating this laser tool. Do not remove any labels from the tool.
- Do not stare directly at the laser beam. Serious eye injury may result.
- Do not project the laser beam directly into the eyes of others.
- Do not set up laser tool at eye level or operate the tool near a reflective surface as the laser beam could be projected into your eyes or into the eyes of others.
- Do not place the laser tool in a manner that may cause someone to unintentionally look into the laser beam.
- Do not attempt to view the laser beam through optical tools such as telescopes as serious eye injury may result.
- Do not operate the tool in explosive environments (i.e., in the presence of gases or flammable liquids).
- Keep the laser tool out of the reach of children and other untrained persons.
- Always turn the laser tool off when not in use or left unattended for a period of time.
- Remove the batteries when storing the tool for an extended time (more than 3 months) to avoid damage to the tool should the batteries deteriorate.
- Do not attempt to repair or disassemble the laser tool. If unqualified persons attempt to repair this tool, warranty will be void.
- Use only original Johnson® parts and accessories purchased from your Johnson® authorized dealer. Use of non-Johnson® parts and accessories will void warranty.



5. Location of Parts/Components



LCD Screen

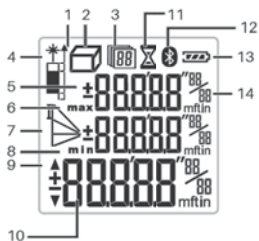

Not all features found on the LCD screen are found in every Johnson Level & Tool Laser Distance Meter. See the notes below for further information.

- | | |
|--|---|
| 1. Measurement Reference Position | 8. Minimum Display |
| 2. Measuring Mode | 9. Stake-out Direction Indicator† |
| 3. Memory (recent measurements)* | 10. Main Screen –
Current Measurement |
| 4. Active Laser Indicator | 11. Countdown Timer* |
| 5. Add and Subtract‡ | 12. Bluetooth® IndicatorΔ |
| 6. Maximum Display | 13. Battery Status Indicator |
| 7. Indirect Measuring Mode
(Pythagoras Measurements)‡ | 14. Secondary Screens
(prior 2 measurements) |

Notes:

* Feature available in the LDM330 only.

† Feature available in the LDM195 and LDM330 only.

Δ Feature found in the LDM130 and LDM330 only.

‡ Feature found in the LDM130, LDM195 and LDM330 only.



6. Battery Installation

To install batteries in the Laser Distance Meter:

1. Unlock the battery cover located at the bottom of the back of the instrument by lifting the metal bar up and over by 180°.
2. Remove the battery cover by sliding the cover towards the bottom of the instrument, as indicated by the arrows, and lifting the cover up.
3. Insert 2 “AAA” batteries into the battery compartment according to the polarity illustrated inside.
4. Replace the battery cover.
5. Lock the battery cover by replacing the metal bar until it is lying flush with the battery cover.



Unlocked Battery Cover



Locked Battery Cover

Current Battery Status

To check the current battery life, press and hold both the **-** and **+** buttons simultaneously for one second. The battery icon will display for approximately 10 seconds.

When the batteries are low, the battery icon will automatically display.



Battery has 100% power



Battery has approximately 60% power



Battery has approximately 25% power



Battery has approximately 5% power,
and new batteries are needed





**Notes:**

- Use only alkaline batteries.
- Remove the batteries when storing the instrument for an extended time (more than 3 months) to avoid damage to the tool should the batteries deteriorate.

7. Operating Instructions

IMPORTANT: It is the responsibility of the user to ensure proper maintenance of the Laser Distance Meter. Conduct periodic test measurements to ensure the instrument is measuring accurately and consistently. This is most important if the instrument has been exposed to extreme temperatures or moisture. Always confirm accuracy before and during important measurements. Keep the Laser Distance Meter optic lens clean and inspect for damage. The Laser Distance Meter is designed to withstand a drop from 3 feet (1 meter). If dropped from a higher distance, the tool's calibration may be affected and it should be tested for accuracy.

Power On/Off the Laser Distance Meter

Press either the  button or the  button to power on the instrument.

Press and hold the  button to power off the instrument.

Automatic Shutoff

Laser will turn off after remaining idle for 2 minutes. Press the  button to re-enable the laser.

Unit will turn off after remaining idle for 5 minutes.







Volume Control

The Laser Distance Meter has three volume settings: high, low and off. When the instrument is powered on, it will default to the most recently used volume setting.

To change the volume setting, press and hold the  button. The unit will cycle through the three settings (S1 = high, S-2 = low, Off = mute) until you release the button.

Bluetooth® Mode

When the instrument is first turned on, the Bluetooth® setting will be off. To turn it on, press and hold the  button until the Bluetooth® icon () flashes at the top of the LCD screen. To turn it off, press and hold the  button until the Bluetooth® icon disappears from the LCD screen.

Measuring Modes

The Laser Distance Meter has 9 measuring modes. When the instrument is powered on, it will default to the Length measuring mode.

1. Length (Single or Continuous)
2. Area/Square
3. Volume/Cube
4. 1-Point Pythagoras
5. 2-Point Pythagoras
6. 3-Point Pythagoras
7. 3-Point Partial Pythagoras
8. Digital Level
9. Stake-out





To select a mode, press the  button. When there is no measuring mode icon shown near the top left of the LCD screen, the instrument is in the Length measuring mode. The selected measuring mode icon will display near the top left of the LCD screen for the Area, Volume, Pythagoras and Digital Level measuring modes. When in the stake-out mode, the main display will have a flashing \pm symbol and will read 0.00, with the hundredths decimal place flashing.

Length (Single or Continuous): No icon displays when the tool is in Length mode.



Area/Square



Volume/Cube



**2-Point
Pythagoras**



**3-Point
Pythagoras**



**3-Point Partial
Pythagoras**



**1-Point
Pythagoras**



Stake-Out



Digital Level







Units of Measure

The Laser Distance Meter has 7 units of measure.

1. Feet in decimal format (e.g., 6.637 ft)
2. Inches in decimal format (e.g., 79.646 in)
3. Feet and inches in 1/32" (e.g., 6'7" 21/32)
4. Inches in 1/32" (e.g., 79" 21/32)
5. Inches in 1/16" (e.g., 79" 11/16)
6. Inches in 1/8" (e.g., 79" 5/8)
7. Meters (e.g., 2.023 m)

To select a unit of measure before making a measurement, press the  button. The word "Unit" will display in the center of the LCD screen, and the unit of measure will display at the bottom right of the LCD screen. Continue to press the  button to scroll through the different units of measure. **OR** after taking a measurement, press the  button repeatedly to scroll through the various units of measurement.

Note: The screen will only display feet and meters in a decimal format in Area or Volume modes.

Measurement Reference Position

Note: Setting the measurement reference correctly is critical to obtaining an accurate measurement, as it establishes the place where a reading of zero (0) is located. If the wrong reference position is selected, the measurement will be off by the length of the tool (4.6" / 4 3/5").





The Laser Distance Meter has two reference positions for measurement, which establish the place where a reading of zero (0) is located. When the instrument is first turned on, it will default to the most recently used position.

1. Front of the unit
2. Back of the unit

To select the desired position, press the  button. The laser indicator icon at the top left of the LCD screen will display the selected position.





Front of Unit Zero
Reference Position



Back of Unit Zero
Reference Position

Using the Timer

1. Press the  button to toggle between the timer settings (2 seconds, 5 seconds, 10 seconds or off).
2. The hourglass icon () will appear at the top of the LCD screen, with the number of seconds (2, 5 or 10) indicated to the left.
3. Aim the Laser Distance Meter so that the laser dot is on the selected target.
4. Keep your position stable and press the  button.
5. The number of seconds displayed on the LCD screen will count down to zero, and the measurement will appear on the main display.











Using the Clipboard

The clipboard feature can be used to store up to 20 measurements.



To save a measurement to the clipboard:

1. After taking your measurement, press the  button.
2. The clipboard icon () will appear at the top center of the LCD screen. The number shown in the icon corresponds to the measurement number (1 through 20).
3. Press the  button to exit the clipboard and make your next measurement.

To view measurements saved to the clipboard:

1. Press and hold the  button.
2. The clipboard icon () will appear at the top center of the LCD screen, showing the most recently saved measurement.
3. Click the  or  button to scroll through earlier/later saved measurements.
4. Click the  button to exit the clipboard.



To clear all measurements from the clipboard:

1. Press and hold the  button to view the clipboard.
2. Press and hold the  button again. “CLA” will appear on the LCD screen, and all saved measurements will be erased.









Length Measurement Mode – Single

1. After turning on the instrument, it will default to the Length mode. If the mode has been changed and you wish to return to the Length mode, press the  button until the measuring mode icon on the LCD screen disappears.
2. After selecting the desired unit of measure and reference position, aim the Laser Distance Meter so that the laser dot is on the selected target.
3. Keep your position stable and press the  button.
4. The measurement will appear on the main display, and the laser will turn off.
5. Press the  button again to take your next Length measurement.







Length Measurement Mode – Continuous

1. After selecting the desired unit of measure and reference position, aim the Laser Distance Meter so that the laser dot is on the selected target.
2. Keep your position stable and press and hold the  button. The Laser Distance Meter will enter continuous length measurement mode.
3. Move the instrument as necessary to the proper distance.
4. Press the  button or  button to pause the measurement. The laser will turn off.
5. To exit the continuous mode and return to the single length measurement mode, press the  button while the tool is paused.



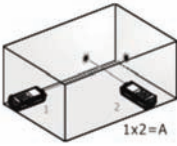







Area/Square Measurement Mode

1. Press the  button once until the Area/Square mode icon () displays near the top left of the LCD screen.
2. After selecting the desired unit of measure and reference position, aim the Laser Distance Meter so that the laser dot is on the selected target to measure the length.

3. Keep your position stable and press the  button. The length measurement will appear above the main display.
4. Aim the Laser Distance Meter so that the laser dot is on the selected target to measure the width.
5. Keep your position stable and press the  button again. The length and width measurements will appear on the secondary screen and the calculated area will appear on the main screen. The laser will turn off.
6. Press the  button again to take your next Area measurement.





Volume/Cube Measurement Mode

1. Press the  button 2 times until the Volume/Cube mode icon () displays near the top left of the LCD screen.
2. After selecting the desired unit of measure and reference position, aim the Laser Distance Meter so that the laser dot is on the selected target to measure the length.
 
3. Keep your position stable and press the  button. The length measurement will appear above the main display
4. Aim the Laser Distance Meter so that the laser dot is on the selected target to measure the height.
5. Keep your position stable and press the  button again. The length and height measurements will appear above the main screen.
6. Aim the Laser Distance Meter so that the laser dot is on the selected target to measure the width.
7. Keep your position stable and press the  button again. The height and width measurements will appear above the main screen, and the calculated volume will appear on the main screen.
8. Press the  button again to take your next Volume measurement.





2-Point Pythagoras Measurement Mode

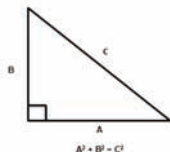

2-Point Pythagoras measurement mode refers to a measurement mode based off the Pythagorean Theorem ($A^2 + B^2 = C^2$). If you know 2 lengths (but not the third), this formula allows you to calculate a missing dimension of a triangle. The



Laser Distance Meter uses this theorem to indirectly measure lengths that are otherwise not directly measureable, enhancing the utility of the tool.



Typically, the Laser Distance Meter is used to measure a height shown above as “B” when there is no target at the top surface at which to aim the laser, such as a tall wall. The measurement can be taken by standing back at some distance “A” and taking measurements of “C” (on the side of the wall) and “A” (aimed level at the wall).

To use the 2-Point Pythagoras measurement mode:

1. Press the  button 3 times until the Pythagoras mode icon () displays at the left of the LCD screen.
2. After selecting the desired unit of measure and reference position, aim the Laser Distance Meter so that the laser dot is on the selected target to measure the length of the hypotenuse (represented by “C” in the figure above and indicated by the flashing lines on the LCD screen).
3. Keep your position stable and press the  button. The “C” measurement will appear above the main display.





4. Aim the Laser Distance Meter so that the laser dot is on the selected target to measure the length of the base (represented by “A” in the figure above).
5. Keep your position stable and press the  button again. The “A” and “C” measurements will appear above the main screen. The indirect height will appear on the main screen (represented by “B” in the figure above). The laser will turn off.
6. Press the  button to clear the display and take your next 2-Point Pythagoras measurement.

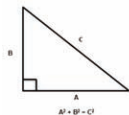

3-Point Pythagoras Measurement Mode

Similar to the 2-Point Pythagoras measurement mode, the 3-Point Pythagoras measurement mode indirectly measures lengths that are otherwise not directly measureable.







Typically, the Laser Distance Meter is used to measure a height shown above as “B” when there is no target at the top surface at which to aim the laser, such as a tall wall, and it is not possible to aim the laser from the ground level. The measurement can be taken by standing back at some distance “A” and taking measurements of “C” and “D” (on the side of the wall) and “A” (aimed level at the wall).

To use the 3-Point Pythagoras measurement mode:

1. Press the  button 4 times until the 3-Point Pythagoras mode icon () displays at the left of the LCD screen.
2. After selecting the desired unit of measure and reference position, aim the Laser Distance Meter so that the laser dot is on the selected target to measure the length “C” in the figure above.



- Keep your position stable and press the  button. The “C” measurement will appear above the main display.
- Aim the Laser Distance Meter so that the laser dot is on the selected target to measure the length “D” in the figure above.
- Keep your position stable and press the  button again. The “D” and “C” measurements will appear above the main display.
- Aim the Laser Distance Meter so that the laser dot is on the selected target to measure the length of the base (represented by “A” in the figure above).
- Keep your position stable and press the  button again. The “A” and “D” measurements will appear above the main screen. The indirect height will appear on the main screen (represented by “B” in the figure above). The laser will turn off.
- Press the  button to clear the display and take your next 3-Point Pythagoras measurement.

3-Point Partial Pythagoras Measurement Mode



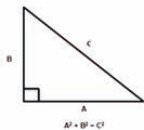



Similar to the 2-Point and 3-Point Pythagoras measurement mode, the 3-Point Partial Pythagoras measurement mode indirectly measures lengths that are otherwise not directly measureable.



Typically, the Laser Distance Meter is used to measure a partial height, shown above as “B”, when there is no target at the top surface at which to aim the laser, such as a tall wall. The measurement can be taken by standing back at some distance “A” and taking measurements of “C” and “D” (on the side of the wall) and “A” (aimed level at the wall).



To use the 3-Point Partial Pythagoras measurement mode:

1. Press the  button 5 times until the 3-Point Partial Pythagoras mode icon () displays at the left of the LCD screen.
2. After selecting the desired unit of measure and reference position, aim the Laser Distance Meter so that the laser dot is on the selected target to measure the length “C” in the figure above.
3. Keep your position stable and press the  button. The “C” measurement will appear above the main display.
4. Aim the Laser Distance Meter so that the laser dot is on the selected target to measure the length “D” in the figure above.
5. Keep your position stable and press the  button again. The “C” and “D” measurements will appear above the main display.
6. Aim the Laser Distance Meter so that the laser dot is on the selected target to measure the length of the base (represented by “A” in the figure above).
7. Keep your position stable and press the  button again. The “D” and “A” measurements will appear above the main screen. The indirect height will appear on the main screen (represented by “B” in the figure above). The laser will turn off.
8. Press the  button to clear the display and take your next 3-Point Partial Pythagoras measurement.









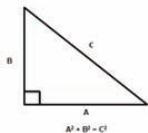

1-Point Pythagoras Measurement Mode

This Laser Distance Meter is equipped with an angle sensor that can be used to both quickly check an angle (like a digital level) or to make more advanced 1-point Pythagoras calculations with only one measured length reference. The 1-Point Pythagoras mode uses mathematical relationships to calculate a distance that cannot otherwise be measured directly by measuring the angle of the tool and the length of a triangle hypotenuse.



To use the 1-Point Partial Pythagoras measurement mode:

1. Press the  button 6 times until the Pythagoras mode icon () displays near the top left of the LCD screen and the current value for the angle is displayed as XX.X°.
2. After selecting the desired unit of measure and reference position, aim the Laser Distance Meter so that the laser dot is on the selected target to measure the length of the hypotenuse. Hold the Laser Distance Meter so that the bottom edge of the tool is roughly horizontal for the most accurate results.
3. Keep your position stable and press the  button. The angle measured will appear above the main display.
4. A length result will be shown on the main screen, and the triangle in the Pythagoras Measurements indicator will flash one leg of the triangle. The measurement result shown corresponds to that length of the triangle you measured (height, width or hypotenuse). Press the  or  button to toggle through the different sides of the triangle.
5. Press the  button to clear the display and take your next 1-Point Pythagoras measurement.













Stake-out Measurement Mode

The Stake-out mode is used when it is necessary to measure a repeating distance interval, such as when installing fence posting every 8 feet. **It is important to have the volume enabled when using the stake-out mode, as the tool will beep to guide you to the correct distance.**

To use the stake-out mode:

1. Set your desired unit of measurement and measurement reference position, as described earlier in this manual.
2. Press the  button 7 times to enter the stake-out mode. The main display will have a flashing \pm symbol and will read 0.00, with the hundredths decimal place flashing. This number indicates your desired stake-out distance. 
3. If you wish to increase or decrease the set stake-out distance by hundredths of a decimal point (the flashing number), press the  button to increase the set stake-out distance or press the  button to decrease the stake-out distance.
4. If you wish to increase or decrease the set stake-out distance by whole numbers, first press the  button. The whole number on the main display will begin flashing. Press the  button to increase the set stake-out distance or press the  button to decrease the stake-out distance.
5. Aim the Laser Distance Meter so that the laser dot is on the selected target.
6. While keeping your position stable, press and hold the  button.





7. The Laser Distance Meter will begin beeping steadily, and 3 numbers will appear on the LCD screen.
- The top number indicates the set stake-out distance that you have set.
 - The middle number indicates the number of stake-out points between the unit and the selected target.
 - The bottom number on the main display indicates the distance between the unit and the selected target.
8. A + or – symbol will flash on the main display to guide you forward or backward, respectively, to the first stake-out point. As you approach the stake-out point, the middle number on the LCD screen will continually update until it reaches a whole number (the stake-out point). The unit will beep at regular intervals until you reach the first stake-out point, at which time it will emit a long beep.
9. Continue following the main display as described in steps 7 and 8 above until you have measured all of your stake-out points.

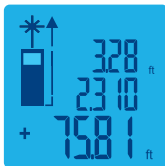



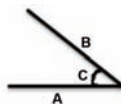

Digital Level Measurement Mode

The Digital Level measurement mode provides an angle measurement.



This laser distance meter can be used as a digital level to measure a vertical angle, shown above as “C.” There are many benefits to using this mode. Over short distances, it can be used for spot checking level of floors, countertops, etc. Over long distances, it can be used to check the angle of rafters or the relative height of two walls, etc. by using the laser beam as a reference.

To use the Digital Level measurement mode:

1. After selecting the desired reference position, press the  button 8 times until the Digital Level mode icon () displays at the left of the LCD screen.
2. The angle will show in the main display and will update continuously as you move the Laser Distance Meter.





Measurement Addition and Subtraction

To add consecutive measurements, complete the following steps:

1. Complete your first measurement
2. Press the **+** button. The first measurement will appear above the main display.
3. Complete your second measurement. The second measurement will appear above the main display, and the sum of the two measurements will appear in the main display.
4. Repeat step 3 above as necessary to add further measurements.

To subtract consecutive measurements, complete the following steps:

1. Complete your first measurement
2. Press the **-** button. The first measurement will appear above the main display.
3. Complete your second measurement. The second measurement will appear above the main display, and the difference of the two measurements will appear in the main display.
4. Repeat step 3 above as necessary to subtract further measurements.













Calibrating the Angle Sensor

This Laser Distance Meter is equipped with highly accurate digital angle sensors for using the 1-Point Pythagoras measurement mode. This sensor should be calibrated regularly for the most accurate results possible.

To calibrate the angle sensor:

1. Find a fairly level horizontal surface such as a countertop, desk, wood floor, etc. The surface does not need to be perfectly level but should be within approximately 2° of level.
2. With the Laser Distance Meter powered off, hold down both the  button and the  button simultaneously.
3. Release the  button.
4. When “CALO” appears on the screen, release the  button.
5. With “CALO” on the screen, position the Laser Distance Meter upright on the surface so that the laser beam is pointing towards the sky and the screen is facing you.
6. Press the  button and then release the Laser Distance Measure so that it is balancing vertically in an upright position. On the screen, “CALO” will change to “CAL 1”, followed by “OK.”
7. Rotate the Laser Distance Meter 180 degrees so it is upright with the laser beam pointing towards the sky and the screen is facing away from you.
8. Press the  button. “CAL 2” will appear on the screen followed by “OK.”
9. Lay the Laser Distance Meter down so that the laser beam is facing away from you and the screen is facing the sky.



10. Press the  button. "CAL 3" will appear on the screen followed by "OK."
11. Rotate the Laser Distance Meter 180 degrees so the laser beam is pointing towards you and the screen is facing the sky.
12. Press the  button. "CAL 4" will appear on the screen followed by "OK."
13. The Laser Distance Meter will power down, and calibration of the angle sensor will be complete.



Cal0:
Stand upright facing you.



Cal1:
Rotate 180° to face away from you.



Cal2:
Lay down flat, LCD away from you.





Cal3:
Rotate 180°, LCD towards you.



8. Using the Bluetooth® Measure-Up™ App

This LDM features Bluetooth® for integration with your Android or iOS smartphone or tablet. The app allows you to photograph and dimension your jobsite. The dimensioned drawings can be saved or exported to email or other popular messaging apps.

To get started, you'll need a device running iOS or Android. Download the free Measure-Up™ app from the App Store or the Play Store.

Power up the LDM and press and hold the Bluetooth® button  until the Bluetooth® indicator on the LDM screen flashes. Keep the LDM in length mode the entire time you use it with the app.

Ensure your smartphone or tablet's Bluetooth® is enabled, then open the Measure-Up™ app and select the Bluetooth® pairing icon . Select the laser distance meter from the list of Bluetooth® devices. You may need to hit the  refresh button in the App to see the device. The next time you pair the same LDM, you can omit this step – you will be prompted to reconnect to the last device, if it is enabled and within range.

Use the camera icon  to take a picture of your jobsite. It is recommended to hold your device in landscape mode for taking the picture because it will maximize the screen area available for dimensioning your drawing. Accept the photo, then begin adding dimension lines. Select the dimension icon  to begin drawing the dimension lines. You can draw arrows, rectangles (for area) or cubes



(for volumes). You can adjust the corners of the rectangles or cubes to adjust for any perspective distortion in your photo by dragging the ends of the line segments. Select the check mark ✓ icon to finish your dimension lines.

Next, take your measurements one at a time on the LDM. The LDM should stay in length mode, even for areas or volumes - the app will calculate these. Each measurement taken will appear on the top right of the display in the app. Click and drag the dimension in the app to the appropriate dimension line in the app to snap the dimension to the dimension line.

To append a voice, text, or video message to the picture, click the  button and select video  , audio  or text .

When you have completed your image, press ✓ to save it. To exit without saving, press  . You can return to your image in the app later, or you can export it by pressing  . It can be emailed, or sent via many popular messaging or storage apps.





9. Tips from the Pros

- Take more than one measurement in situations where accuracy is critical.
- Take 3-4 measurements from the same position to compare the consistency of each reading.
- To accurately measure objects lacking an inside corner from the rear of the instrument, use a scrap piece of drywall or other flat material to extend the corner. Butt the Laser Distance Meter up to the material (as shown).
- If error message ERR 2 appears, place a white sheet of paper or reflective presse over the targeted measuring surface to improve the return signal.
- Be aware that, when outdoors, the working range of the tool decreases due to ambient light.
- To make the laser beam more visible, aim it down in front of you and then follow it with your eyes as you move it towards the desired target.
- When making Pythagoras measurements, make sure that during your second measurement you hold the tool as flat as possible for the most accurate measurements.
- Calibrate the angle sensor every day that you plan to take 1-point Pythagoras measurements or on days when the temperature varies considerably.





- Use 2-point or 3-point Pythagoras measurements when possible; they are generally more accurate than 1-point Pythagoras calculations.
- Use the corner hook and corner extension to simplify measurements.
- When working outside, a tripod will help stabilize the Laser Distance Meter for greater accuracy, particularly when longer measurements are needed.
- Use the self-timer to reduce the vibrations caused by pressing the button, especially when longer measurements are needed.

10. Care and Handling

- This Laser Distance Meter unit is a precision tool that must be handled with care.
- Avoid exposing unit to shock vibrations and extreme temperatures.
- Remove the batteries when storing the unit for an extended time (more than 3 months) to avoid damage to the unit should the batteries deteriorate.
- Avoid getting the unit wet.
- Keep the laser unit dry and clean, especially the laser output window. Remove any moisture or dirt with a soft, dry cloth.
- Do not use harsh chemicals, strong detergents or cleaning solvents to clean the unit.





11. Troubleshooting Guide

This section is designed to help you diagnose and troubleshoot common problems that prevent the Laser Distance Meter from working properly.

If the Laser Distance Meter returns an ERR code (display shows ERR plus a number from 1 to 6), please *refer to Section 4* of this manual for possible resolutions. If your Laser Distance Meter fails to operate in any other way, please refer to the following troubleshooting guide for some suggestions on how to diagnose the problem.

Symptom	Possible Cause	Solution
Will not turn on	Batteries missing or depleted	Change the batteries
	Polarity reversed	Check battery polarity
Turns off after a short time	Batteries depleted	Change the batteries
Measurement seems incorrect	Incorrect reference used	Set the reference position to the front rear edge of the tool, as appropriate
	Angle sensor requires calibration	Calibrate the angle sensor (refer to the <i>Calibrating the Angle Sensor</i> section of this manual)





12. Technical Specifications

Laser Wavelength	650 nm
Laser Classification	II
Maximum Power Output	$\leq 1\text{mW}$
Typical Accuracy*	$\pm 1/16''$ over the full working range
Accuracy at Unfavorable Conditions**	$\pm 3/16''$ over the full working range
Angle Sensor Accuracy	$0^\circ, 90^\circ - 0.2^\circ$; all others $- 0.5^\circ$
Typical Measuring Range*	2'' - 330'
Typical Interior Range*	2'' - 330'
Range at Unfavorable Conditions**	2'' - 135'
Bluetooth®	Yes
Angle Sensor	No
Operating Modes	Single, Continuous, Area, Volume, 1-Point Pythagoras, 2-Point Pythagoras, 3-Point Pythagoras, 3-Point Partial Pythagoras, Stake-out
Units	ft, in, m, 1/8'', 1/16'', 1/32''
Power Supply	2 "AAA" alkaline batteries (included)
Battery Life	Minimum 10 hours/10,000 measurements





Operating Temperature Range	23°F - 104°F
Storage Temperature Range	-4°F - 160°F
Dimensions	4.6" x 1.9" x 1.2"
Weight	4.38 oz. including batteries; 3.63 oz. excluding batteries
IP Rating	IP 54

*Tested per ISO 16331-1.

**Per ISO16331-1, unfavorable conditions are designed to simulate bright sunlight and give an approximate indication of the working range of the tool outdoors on a bright, sunny day. Overcast or darker days will offer a longer working range.





13. Product Warranty

Johnson Level & Tool offers a two year limited warranty on each of its products. You can obtain a copy of the limited warranty for a Johnson Level & Tool product by contacting Johnson Level & Tool's Customer Service Department, as provided below, or by visiting our web site at www.johnsonlevel.com. The limited warranty for each product contains various limitations and exclusions.

Do not return this product to the store/retailer or place of purchase. Non-warranty repairs and course calibration must be done by an authorized Johnson® service center or Johnson Level & Tool's limited warranty, if applicable, will be void and there will be NO WARRANTY. Contact one of our service centers for all non-warranty repairs. A list of service centers can be found on our web site at www.johnsonlevel.com or by calling our Customer Service Department. Contact our Customer Service Department for Return Material Authorization (RMA) for warranty repairs (manufacturing defects only). Proof of purchase is required.

NOTE: The user is responsible for the proper use and care of the product. It is the responsibility of the user to verify the calibration of the instrument before each use.

For further assistance, or if you experience problems with this product that are not addressed in this instruction manual, please contact our Customer Service Dept.

In the U.S., contact Johnson Level & Tool's Customer Service Department at 888-9-LEVELS.

In Canada, contact Johnson Level & Tool's Customer Service Department at 800-346-6682.





14. Warranty Registration

Please register within 30 days of purchase. Registering ensures we have your information on file for warranty service even if you lose your receipt, and lets us contact you if there is ever a product recall. We will never sell your information and only send you marketing information if you opt-in.

To register, go to www.johnsonlevel.com/register.



15. Accessories

Johnson® accessories are available for purchase through authorized Johnson® dealers. Use of non-Johnson® accessories will void any applicable limited warranty and there will be NO WARRANTY. If you need any assistance in locating any accessories, please contact our Customer Service Department.

In the U.S., contact Johnson Level & Tool's Customer Service Department at 888-9-LEVELS.

In Canada, contact Johnson Level & Tool's Customer Service Department at 800-346-6682.



