

GeoMax Zone80 DG

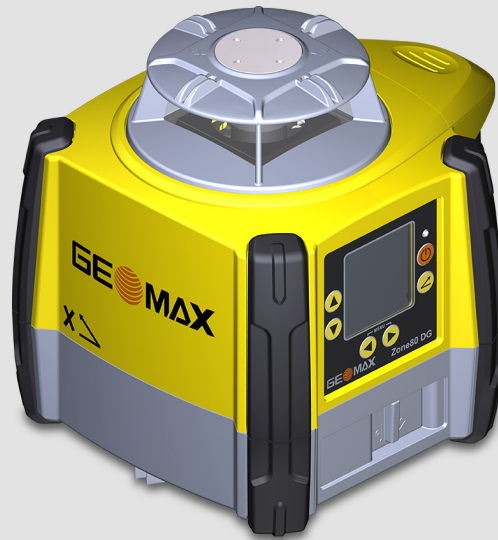

SOLD & SERVICED BY
Survey Instrument Sales
Helping You Measure the World
24037 Acacia Redford, MI 48239 • 313-535-5252
www.SurveyInstrumentSales.com

User Manual

Version 1.0
English



Introduction

Purchase

Congratulations on the purchase of a GeoMax Rotating Laser product.



This manual contains important safety directions as well as instructions for setting up the product and operating it. Refer to "1 Safety Directions" for further information.

Read carefully through the User Manual before you switch on the product.



The content of this document is subject to change without prior notice. Ensure that the product is used in accordance with the latest version of this document.

Updated versions are available for download at the following Internet address:

<https://partners.geomax-positioning.com/downloads.htm>

Product identification

The model and serial number of your product are indicated on the type plate.

Always refer to this information when you need to contact your agency or GeoMax authorised service centre.

Validity of this manual

This manual applies to the Zone80 DG lasers. Differences between the models are marked and described.

Available documentation



Name	Description/Format		
Zone80 DG Quick Guide	Provides an overview of the product together with technical data and safety directions. Intended as a quick reference guide.	✓	✓
Zone80 DG User Manual	All instructions required in order to operate the product to a basic level are contained in the User Manual. Provides an overview of the product together with technical data and safety directions.	-	✓
Zone80 DG Basic Applications	Provides an overview of the basic general construction, leveling and slope applications that can be done using the product.	✓	✓

Table of Contents

1	Safety Directions	5
1.1	General	5
1.2	Definition of Use	5
1.3	Limits of Use	6
1.4	Responsibilities	6
1.5	Hazards of Use	6
1.6	Laser Classification	9
	1.6.1 General	9
	1.6.2 Zone80 DG	9
1.7	Electromagnetic Compatibility EMC	10
1.8	FCC Statement, Applicable in U.S.	11
2	Description of the System	14
2.1	System Components	14
2.2	Zone80 DG Laser Components	15
2.3	Case Components	15
2.4	Setup	15
3	Operation	17
3.1	User Interface	17
3.2	Turning the Zone80 DG on and off	17
3.3	The LCD Display	18
3.4	Grade Entry	18
3.5	Axis Identification	20
3.6	Conversion of Slope Into Percent of Grade	20
3.7	Alignment of the Axes	21
3.8	Precise Alignment of the Axes	21
3.9	Laydown Operation	22
4	ZRC60 Remote Control	23
4.1	Description of the Remote Control	23
4.2	Pairing the Zone80 DG with the ZRC60 Remote Control	24
4.3	Connecting Screens for the Remote Control	25
5	Receivers	26
5.1	Overview	26
	5.1.1 ZRP105 Receiver	26
	5.1.2 ZRD105, Digital Receiver	27
	5.1.3 ZRD105B, Digital RF Receiver	28
5.2	Using the ZRD105B Receiver with the Zone80 DG	28
5.3	Pairing the ZRD105B with the Zone80 DG	28
6	Zone80 DG Menu	30
6.1	Access and Navigation	30
6.2	Menu Set 1	31
6.3	Menu Set 2	34
6.4	Menu Set 3	38
7	ZRC60 Menu	43
8	Applications	44
8.1	Agriculture levelling	44
8.2	Checking Grades	44
8.3	Entering Grades	45
8.4	Beam Catching (Grade Matching)	46
8.5	Beam Lock (Grade Matching and Monitoring)	46
9	Batteries	48
9.1	Operating Principles	48
9.2	Battery for Zone80 DG	48

10	Accuracy Adjustment	50
10.1	Checking the Level Accuracy	50
10.2	Adjusting the Self-Levelling Accuracy	51
10.3	Adjusting the Vertical Accuracy	52
11	Troubleshooting	54
12	Care and Transport	57
12.1	Transport	57
12.2	Storage	57
12.3	Cleaning and Drying	57
13	Technical Data	59
13.1	Conformity to National Regulations	59
13.2	Dangerous Goods Regulations	59
13.3	General Technical Data of the Product	59
13.3.1	ZRC60 Remote Control	61

1 Safety Directions

1.1 General

Description

The following directions enable the person responsible for the product, and the person who actually uses the equipment, to anticipate and avoid operational hazards.

The person responsible for the product must ensure that all users understand these directions and adhere to them.

About warning messages





Warning messages are an essential part of the safety concept of the instrument. They appear wherever hazards or hazardous situations can occur.

Warning messages...

- make the user alert about direct and indirect hazards concerning the use of the product.
- contain general rules of behaviour.

For the users' safety, all safety instructions and safety messages shall be strictly observed and followed! Therefore, the manual must always be available to all persons performing any tasks described here.

DANGER, WARNING, CAUTION and **NOTICE** are standardised signal words for identifying levels of hazards and risks related to personal injury and property damage. For your safety, it is important to read and fully understand the following table with the different signal words and their definitions! Supplementary safety information symbols may be placed within a warning message as well as supplementary text.

Type	Description
 DANGER	Indicates an imminently hazardous situation which, if not avoided, will result in death or serious injury.
 WARNING	Indicates a potentially hazardous situation or an unintended use which, if not avoided, could result in death or serious injury.
 CAUTION	Indicates a potentially hazardous situation or an unintended use which, if not avoided, may result in minor or moderate injury.
NOTICE	Indicates a potentially hazardous situation or an unintended use which, if not avoided, may result in appreciable material, financial and environmental damage.
	Important paragraphs which must be adhered to in practice as they enable the product to be used in a technically correct and efficient manner.

1.2 Definition of Use

Intended use

- The product casts a horizontal laser plane or a laser beam for the purpose of alignment.
- The laser beam can be detected by means of a laser detector.
- Remote control of product.
- Data communication with external appliances.

Reasonably foreseeable misuse

- Use of the product without instruction.
- Use outside of the intended use and limits.
- Disabling safety systems.
- Removal of hazard notices.
- Opening the product using tools, for example screwdriver, unless this is permitted for certain functions.
- Modification or conversion of the product.
- Use after misappropriation.
- Use of products with obvious damages or defects.
- Use with accessories from other manufacturers without the prior explicit approval of GeoMax.
- Inadequate safeguards at the working site.
- Deliberate dazzling of third parties.
- Controlling of machines, moving objects or similar monitoring application without additional control and safety installations.

1.3

Limits of Use

Environment

Suitable for use in an atmosphere appropriate for permanent human habitation: not suitable for use in aggressive or explosive environments.

WARNING

Working in hazardous areas, or close to electrical installations or similar situations.

Life Risk.

Precautions:

- ▶ Local safety authorities and safety experts must be contacted by the person responsible for the product before working in such conditions.

1.4

Responsibilities

Manufacturer of the product

GeoMax AG, CH-9443 Widnau, hereinafter referred to as GeoMax, is responsible for supplying the product, including the user manual and original accessories, in a safe condition.

Person responsible for the product

The person responsible for the product has the following duties:

- To understand the safety instructions on the product and the instructions in the User Manual.
- To ensure that it is used in accordance with the instructions.
- To be familiar with local regulations relating to safety and accident prevention.
- To inform GeoMax immediately if the product and the application becomes unsafe.
- To ensure that the national laws, regulations and conditions for the operation of the product are respected.

1.5

Hazards of Use

NOTICE

Dropping, misusing, modifying, storing the product for long periods or transporting the product

Watch out for erroneous measurement results.

Precautions:

- ▶ Periodically carry out test measurements and perform the field adjustments indicated in the User Manual, particularly after the product has been subjected to abnormal use as well as before and after important measurements.

⚠ DANGER

Risk of electrocution

Because of the risk of electrocution, it is dangerous to use poles, levelling staffs and extensions in the vicinity of electrical installations such as power cables or electrical railways.

Precautions:

- ▶ Keep at a safe distance from electrical installations. If it is essential to work in this environment, first contact the safety authorities responsible for the electrical installations and follow their instructions.



NOTICE

Remote control of product

With the remote control of products, it is possible that extraneous targets will be picked out and measured.

Precautions:

- ▶ When measuring in remote control mode, always check your results for plausibility.

⚠ WARNING

Lightning strike

If the product is used with accessories, for example masts, staffs, poles, you may increase the risk of being struck by lightning.

Precautions:

- ▶ Do not use the product in a thunderstorm.

⚠ WARNING

Inadequate securing of the working site.

This can lead to dangerous situations, for example in traffic, on building sites and at industrial installations.

Precautions:

- ▶ Always ensure that the working site is adequately secured.
- ▶ Adhere to the regulations governing safety, accident prevention and road traffic.

⚠ CAUTION

Not properly secured accessories.

If the accessories used with the product are not properly secured and the product is subjected to mechanical shock, for example blows or falling, the product may be damaged or people can sustain injury.

Precautions:

- ▶ When setting up the product, make sure that the accessories are correctly adapted, fitted, secured, and locked in position.
- ▶ Avoid subjecting the product to mechanical stress.

⚠ WARNING

Inappropriate mechanical influences to batteries

During the transport, shipping or disposal of batteries it is possible for inappropriate mechanical influences to constitute a fire hazard.

Precautions:

- ▶ Before shipping the product or disposing it, discharge the batteries by the product until they are flat.
- ▶ When transporting or shipping batteries, the person in charge of the product must ensure that the applicable national and international rules and regulations are observed.
- ▶ Before transportation or shipping, contact your local passenger or freight transport company.

⚠ WARNING

Distraction/loss of attention

During dynamic applications, for example stakeout procedures, there is a danger of accidents occurring if the user does not pay attention to the environmental conditions around, for example obstacles, excavations or traffic.

Precautions:

- ▶ The person responsible for the product must make all users fully aware of the existing dangers.

⚠ WARNING

Unauthorised opening of the product

Either of the following actions may cause you to receive an electric shock:

- Touching live components
- Using the product after incorrect attempts were made to carry out repairs

Precautions:

- ▶ Do not open the product!
- ▶ Only GeoMax authorised service centres are entitled to repair these products.

⚠ WARNING

If the product is improperly disposed of, the following can happen:

- If polymer parts are burnt, poisonous gases are produced which may impair health.
- If batteries are damaged or are heated strongly, they can explode and cause poisoning, burning, corrosion or environmental contamination.
- By disposing of the product irresponsibly you may enable unauthorised persons to use it in contravention of the regulations, exposing themselves and third parties to the risk of severe injury and rendering the environment liable to contamination.

Precautions:

▶

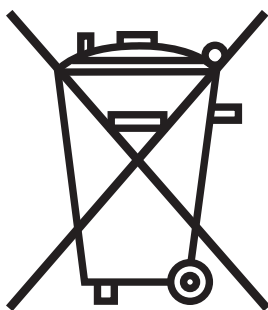

The product must not be disposed with household waste. Dispose of the product appropriately in accordance with the national regulations in force in your country. Always prevent access to the product by unauthorised personnel.

Product-specific treatment and waste management information can be downloaded from the GeoMax website at <http://www.geomax-positioning.com/treatment> or received from your GeoMax distributor.

⚠ WARNING

Improperly repaired equipment

Risk of injuries to users and equipment destruction due to lack of repair knowledge.

Precautions:

- ▶ Only authorised GeoMax Service Centres are entitled to repair these products.

⚠ WARNING

Exposure of batteries to high mechanical stress, high ambient temperatures or immersion into fluids

This can cause leakage, fire or explosion of the batteries.

Precautions:

- ▶ Protect the batteries from mechanical influences and high ambient temperatures. Do not drop or immerse batteries into fluids.

⚠ WARNING

Short circuit of battery terminals

If battery terminals are short circuited e.g. by coming in contact with jewellery, keys, metallised paper or other metals, the battery can overheat and cause injury or fire, for example by storing or transporting in pockets.

Precautions:

- ▶ Make sure that the battery terminals do not come into contact with metallic objects.

1.6

Laser Classification

1.6.1

General

General

The following chapters provide instructions and training information about laser safety according to international standard IEC 60825-1 (2014-05) and technical report IEC TR 60825-14 (2004-02). The information enables the person responsible for the product and the person who actually uses the equipment, to anticipate and avoid operational hazards.



According to IEC TR 60825-14 (2004-02), products classified as laser class 1, class 2 and class 3R do not require:

- laser safety officer involvement,
- protective clothes and eyewear,
- special warning signs in the laser working area

if used and operated as defined in this User Manual due to the low eye hazard level.



National laws and local regulations could impose more stringent instructions for the safe use of lasers than IEC 60825-1 (2014-05) and IEC TR 60825-14 (2004-02).

1.6.2

Zone80 DG

General

The rotating laser built into the product produces a visible laser beam which emerges from the rotating head.

The laser product described in this section is classified as laser class 1 in accordance with:

- IEC 60825-1 (2014-05): "Safety of laser products"

These products are safe for momentary exposures but can be hazardous for deliberate staring into the beam. The beam may cause dazzle, flash-blindness and after-images, particularly under low ambient light conditions.

Zone80 DG:

Description	Value
Maximum average radiant output power	0.4 mW / 2.2 mW

Description	Value
Pulse duration (effective)	500 ms / 2.9 ms, 1.4 ms
Pulse repetition frequency	1 Hz / 5 Hz, 10 Hz, 20 Hz
Beam divergence	0.2 mrad
Wavelength	635 nm

Labelling

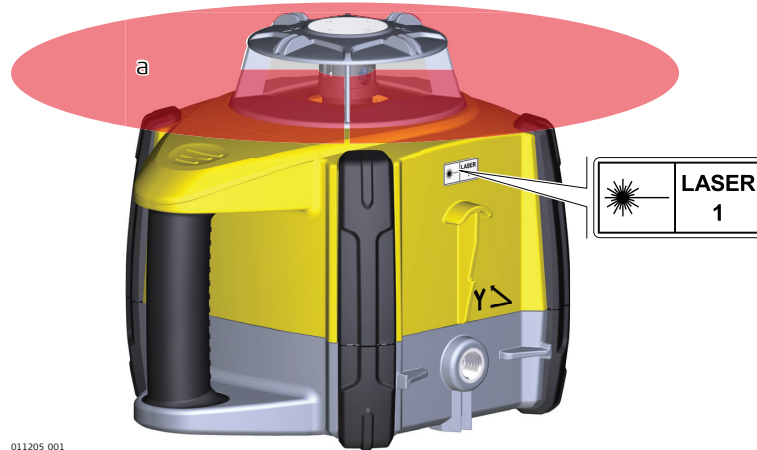

011205.001

a) Laser beam

1.7

Electromagnetic Compatibility EMC

Description

The term Electromagnetic Compatibility is taken to mean the capability of the product to function smoothly in an environment where electromagnetic radiation and electrostatic discharges are present, and without causing electromagnetic disturbances to other equipment.

WARNING

Electromagnetic radiation

Electromagnetic radiation can cause disturbances in other equipment.

Precautions:

- ▶ Although the product meets the strict regulations and standards which are in force in this respect, GeoMax cannot completely exclude the possibility that other equipment may be disturbed.

CAUTION

Use of the product with accessories from other manufacturers. For example field computers, personal computers or other electronic equipment, non-standard cables or external batteries

This may cause disturbances in other equipment.

Precautions:

- ▶ Use only the equipment and accessories recommended by GeoMax.
- ▶ When combined with the product, they meet the strict requirements stipulated by the guidelines and standards.
- ▶ When using computers, two-way radios or other electronic equipment, pay attention to the information about electromagnetic compatibility provided by the manufacturer.

 **CAUTION**

Intense electromagnetic radiation. For example, near radio transmitters, transponders, two-way radios or diesel generators

Although the product meets the strict regulations and standards which are in force in this respect, GeoMax cannot completely exclude the possibility that function of the product may be disturbed in such an electromagnetic environment.

Precautions:

- ▶ Check the plausibility of results obtained under these conditions.

 **CAUTION**

Electromagnetic radiation due to improper connection of cables

If the product is operated with connecting cables attached at only one of their two ends, for example external supply cables, interface cables, the permitted level of electromagnetic radiation may be exceeded and the correct functioning of other products may be impaired.

Precautions:

- ▶ While the product is in use, connecting cables, for example product to external battery, product to computer, must be connected at both ends.

 **WARNING**

Use of product with radio or digital cellular phone devices

Electromagnetic fields can cause disturbances in other equipment, in installations, in medical devices, for example pacemakers or hearing aids and in aircrafts. Electromagnetic fields can also affect humans and animals.

Precautions:

- ▶ Although the product meets the strict regulations and standards which are in force in this respect, GeoMax AG cannot completely exclude the possibility that other equipment can be disturbed or that humans or animals can be affected.
- ▶ Do not operate the product with radio or digital cellular phone devices in the vicinity of filling stations or chemical installations, or in other areas where an explosion hazard exists.
- ▶ Do not operate the product with radio or digital cellular phone devices near to medical equipment.
- ▶ Do not operate the product with radio or digital cellular phone devices in aircrafts.
- ▶ Do not operate the product with radio or digital cellular phone devices for long periods with the product immediately next to your body.

1.8

FCC Statement, Applicable in U.S.

 **WARNING**

This equipment has been tested and found to comply with the limits for a Class B digital device, pursuant to part 15 of the FCC rules.

These limits are designed to provide reasonable protection against harmful interference in a residential installation.

This equipment generates, uses and can radiate radio frequency energy and, if not installed and used in accordance with the instructions, may cause harmful interference to radio communications. However, there is no guarantee that interference will not occur in a particular installation.

If this equipment does cause harmful interference to radio or television reception, which can be determined by turning the equipment off and on, the user is encouraged to try to correct the interference by one or more of the following measures:

- Reorient or relocate the receiving antenna.
- Increase the separation between the equipment and the receiver.
- Connect the equipment into an outlet on a circuit different from that to which the receiver is connected.
- Consult the dealer or an experienced radio/TV technician for help.

 **CAUTION**

Changes or modifications not expressly approved by GeoMax for compliance could void the user's authority to operate the equipment.

Labelling Zone80 DG



18464_001

Labelling receiver

ZRP105:

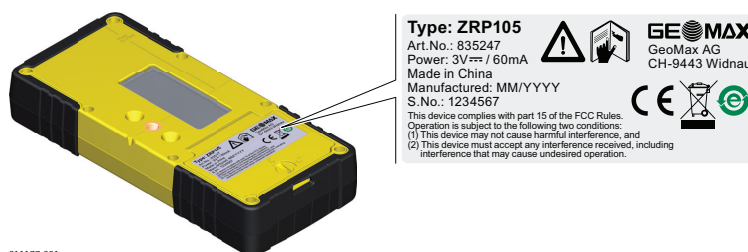

011177_001

Labelling receiver

ZRD105:

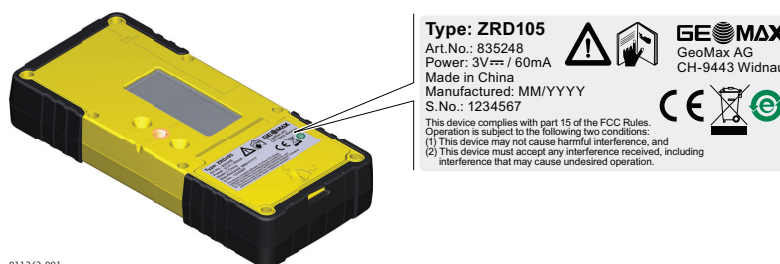

011243_001

Labelling receiver

ZRD105B:

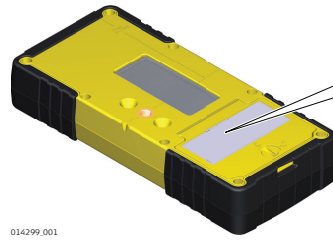

014299.001

Model: ZRD105B
Art.No.: 855671
Power: 3V / 60mA
Made in China
Manufactured: MM/YYYY
S.No.: 1234567

FCC ID: RFD ID-CT100 IC: 3177A-CT100

GEOMAX
GeoMax AG
CH-9443 Widnau

This device complies with part 15 of the FCC Rules. Operation is subject to the following two conditions:
(1) This device may not cause harmful interference, and
(2) This device must accept any interference received, including interference that may cause undesired operation.

Labelling ZRC60

ZRC60

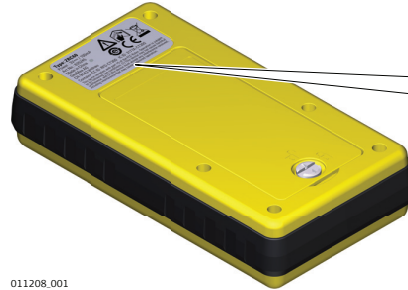

011208.001

Type: ZRC60
Power: 3V / 100mA
Art.No.: 835245
Made in China
GeoMax AG
CH-9443 Widnau

Contains FCC ID: RFD-CT300 IC ID: 3177A-CT300

This device complies with part 15 of the FCC Rules. Operation is subject to the following two conditions: (1) This device may not cause harmful interference, and (2) this device must accept any interference received, including interference that may cause undesired operation.

2 Description of the System

2.1 System Components

General description

The Zone80 DG is a laser tool for general construction, levelling and slope applications such as:

- Setting forms,
- Agricultural levelling applications,
- Levelling to grade,
- Controlling grade levelling,
- Controlling depths for excavations.

If set up within the self-levelling range, the Zone80 DG automatically levels to create an accurate horizontal, vertical or sloped plane of laser light.

Once the Zone80 DG has levelled, the head starts rotating and the Zone80 DG is ready for use.

30 seconds after the Zone80 DG has completed the levelling, the H.I.Alert system becomes active and protects the Zone80 DG against changes in elevation caused by movement of the tripod to ensure accurate work.

Area of application

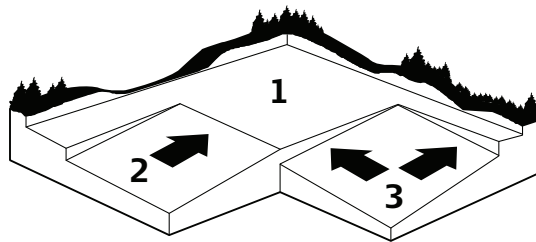

The Zone80 DG is a dual grade laser; it produces an accurate plane of laser light for applications which require level (1), single slope (2) or dual slope (3).

Available system components

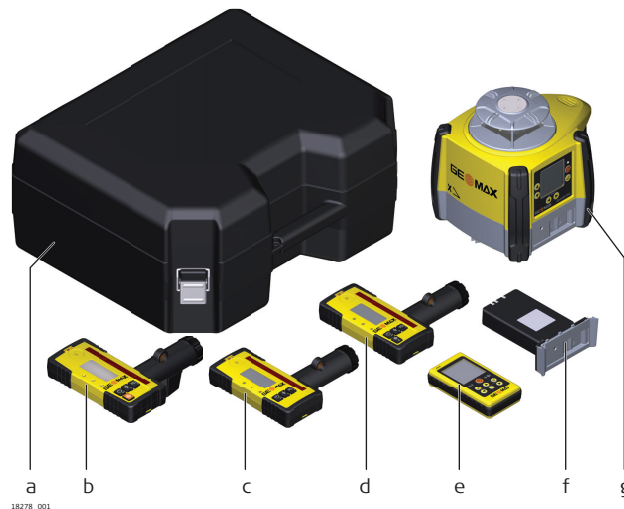

- a Container
- b ZRD105B receiver
- c ZRP105 receiver
- d ZRD105 receiver
- e ZRC60 remote control
- f Li-Ion battery
- g Zone80 DG



The delivered components depend on the package ordered.

2.2

Zone80 DG Laser Components

Laser components



- a Plate for optional scope
- b Carry handle
- c LCD display
- d Control panel
- e Battery compartment
- f Charge LED

2.3

Case Components

Case components

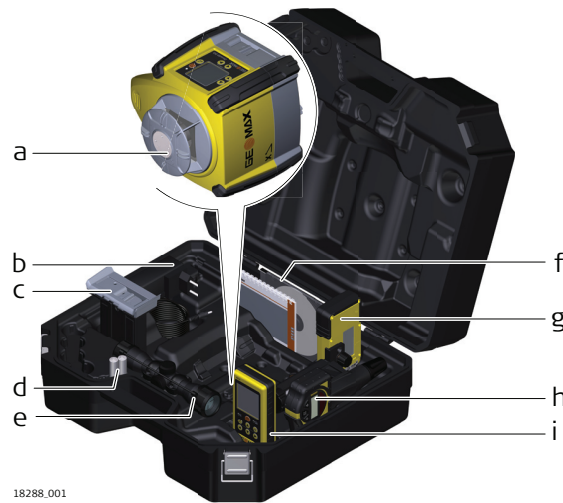

- a Zone80 DG laser
- b Charger
- c Li-Ion battery pack
- d 2x AA-cell battery
- e Optional scope assembly
- f User Manual/CD
- g Receiver mounted on the bracket
- h Second receiver (can be purchased separately)
- i ZRC60 remote control

2.4

Setup

Location

- Keep the location clear of possible obstructions that could block or reflect the laser beam.
- Place the Zone80 DG on stable ground. Ground vibration and extremely windy conditions can affect the operation of the Zone80 DG.
- When working in a very dusty environment place the Zone80 DG up-wind so the dirt is blown away from the laser.

Setting up on a tripod



1. Set up the tripod.

 2. Place the Zone80 DG on the tripod.

 3. Tighten the screw on the underside of the tripod to secure the Zone80 DG on the tripod.
- Attach the Zone80 DG securely to a tripod or laser trailer, or mount on a stable level surface.
 - Always check the tripod or laser trailer before attaching the Zone80 DG. Make sure all screws, bolts and nuts are tight.
 - If a tripod has chains, they should be slightly loose to allow for thermal expansion during the day.
 - Secure the tripod on extremely windy days.
-

3

Operation

3.1

User Interface

Overview

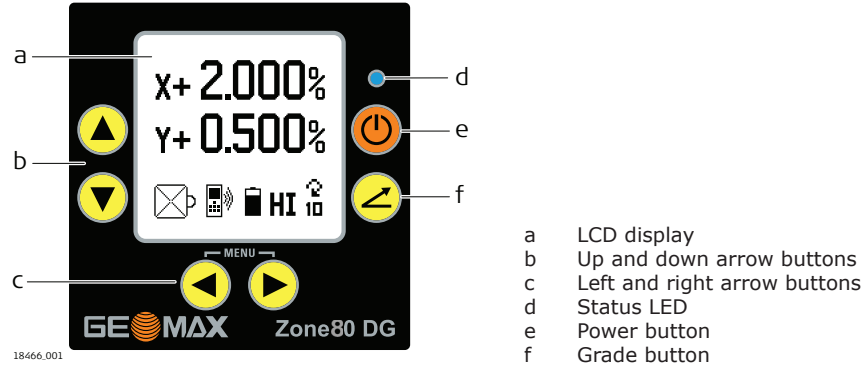

Description

Component	Function
LCD display	Displays all required user information.
Grade button	Press to start grade entry mode.
Left and right arrow buttons	Press to display and move the cursor for grade entry. Press both simultaneously to enter the Zone80 DG menu.
Up and down arrow buttons	Press to change the grade displayed. Press both simultaneously to reset the grade value to zero.
Power button	Press to turn on or off the Zone80 DG.
Status LED	Indicates the level status of the Zone80 DG.

3.2

Turning the Zone80 DG on and off

Turn on and off

Press the Power button to turn the Zone80 DG on or off.

After turning on:

- The LCD display turns on and displays the current status of the Zone80 DG.
- If set up within the $\pm 6^\circ$ self-levelling range (horizontal or vertical), the Zone80 DG automatically levels to create an accurate horizontal plane of laser light.
- Once levelled, the head starts rotating and the Zone80 DG is ready for use.
- The H.I.Alert system becomes active 30 seconds after completing the self-levelling. The H.I.Alert system protects the Zone80 DG against changes in elevation caused by any movement or settling of the tripod.
- The self-levelling system and the H.I.Alert function continue to monitor the position of the laser beam to ensure consistent and accurate work.



The H.I.Alert function turns on automatically every time the Zone80 DG is turned on.

3.3

The LCD Display

Main display

The LCD display shows all the information that is required to operate the Zone80 DG.

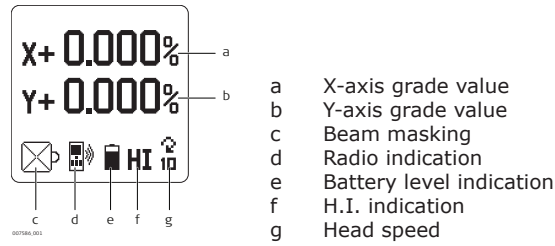

Start-up screens



When the Zone80 DG is turned on, the GeoMax Start-up screen is shown followed by the Zone80 DG Information screen displaying the following information:

- Model and type
- Serial number
- Software revision level
- Hours of use

GeoMax Start-up

3.4

Grade Entry

Direct grade entry

1. To start grade entry mode, press the Grade button once.
 To restore the last set grade(s), press and hold the Grade button for 1.5 seconds.

2. *The X-axis grade value is displayed:*

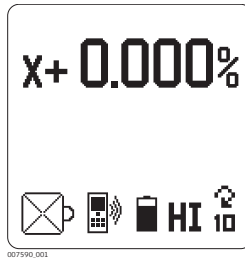

3. To change the grade value, press the Up or Down Arrow buttons.
4. To enter grade on the Y-axis, press the Grade button a second time.

Only the Y-axis grade value is displayed:



To change the grade value, press the Up or Down Arrow buttons.

To exit grade entry mode, press the Grade button until the main display is shown.
OR:
Wait for 8 seconds. The Zone80 DG automatically returns to the main display.

Grade entry by digit

While in grade entry mode, you can easily change the plus/minus sign or individual digits.

1. Press the Grade button to enter the grade entry mode.
2. Press the Left or Right Arrow buttons to create a cursor. The cursor always appears on the plus/minus sign.

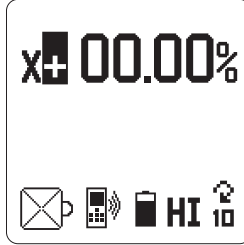

3. Press the Up or Down Arrow buttons to change the plus/minus sign.
4. Press the Left or Right Arrow buttons to move the cursor.

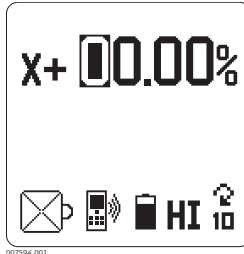

Press the Up or Down Arrow buttons to change a digit.

To exit grade entry mode, press the Grade button until the main display is shown.
OR:
Wait for 8 seconds. The Zone80 DG automatically returns to the main display.

Reset grade value to zero

While in grade entry mode, you can quickly change the grade value back to zero by pressing the Up/Menu button and Down/Sleep button simultaneously.

Grade capability

The Zone80 DG can have up to 10.00% grade simultaneously in both the X and Y axes or up to 15.00% grade in one axis.

Entering grades above 10.00% in one axis is only possible if the cross axis grade is $\pm 3\%$ or lower.



If you try to enter grades greater than 3% or 10%, a notice appears on the screen when you press the button.

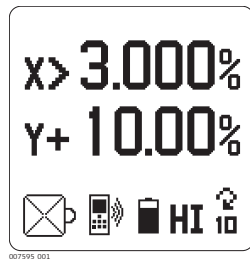

X > 3.000%

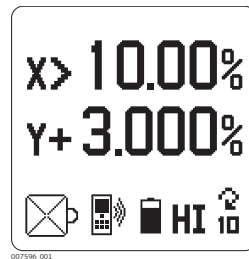

X > 10.00%

Grade swap

The grade in the X and Y axes can be swapped from positive to negative by changing the plus/minus sign in grade entry mode. Refer to Grade entry by digit.

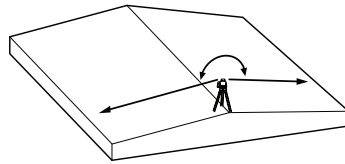

3.5

Axis Identification

Axis identification

When entering grade, it is important to know the correct direction in which the grade is being entered.

Refer to the following illustration to identify the correct directions of the axes.

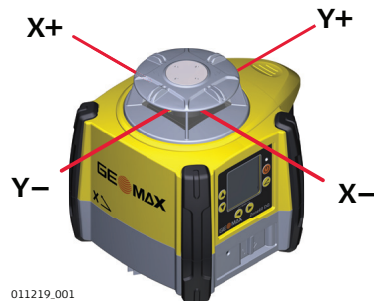

011219.001

3.6

Conversion of Slope Into Percent of Grade

Conversion of slope

Slope: The change in elevation per unit of measure (foot, metre, etc.)

Percent of Grade: The change in elevation per 100 units of measure (feet, metre, etc.)

Calculating percent of grade from slope:

$$[\text{Slope}] \times 100 = [\text{Percent of Grade}]$$

Example:

Slope	= 0.0059
Conversion	= 0.0059 x 100
Percent of Grade	= 0.590%

3.7

Alignment of the Axes

Aligning X- and Y-axis

After the desired grade is correctly set in the display, align the X- and Y-axis to the jobsite.



Ensure that the bubble of the circular level is positioned near the centre of the circle for maximum self-levelling capability.



Ensure that the Zone80 DG is properly positioned over a control point.

The direction of the X-Axis is seen from the front of the Zone80 DG, sighting over the top of the Zone80 DG.

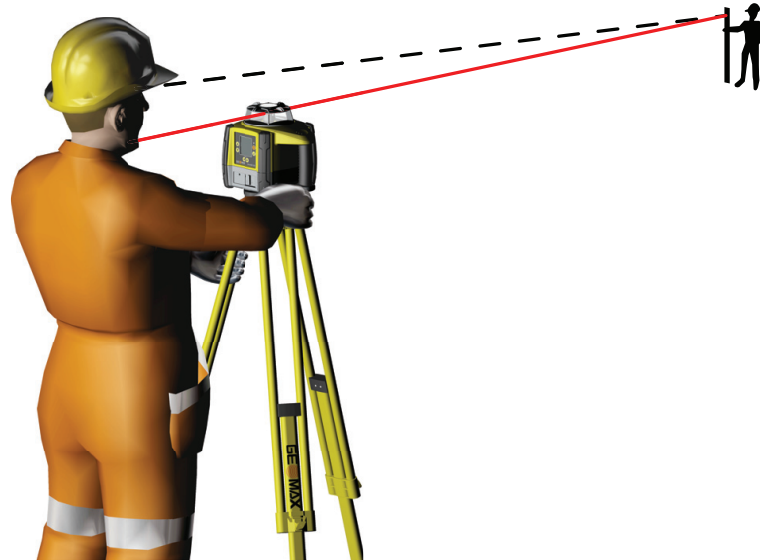

011220.001

Rotate the Zone80 DG slightly until the alignment marks are aligned with your second control point.

Once the Zone80 DG is aligned, you can start working.

3.8

Precise Alignment of the Axes

Precisely aligning X- and Y-axis

Under most conditions, the raised alignment marks on the top of the Zone80 DG are adequate for alignment of the axes. For a more precise alignment, you can use the following procedure.

Objective of a precise alignment:

- To establish Point A on the Y-axis as a reference and take an elevation reading.
- To enter grade into the X-axis and then adjust the position of the laser until the original elevation at Point A is again found.

1. With 0.000% grade in both axes, set up the Zone80 DG directly over a grade stake and roughly align the Y-axis to a second grade stake (Point A).

2. Take an elevation reading at Point A using the receiver and a survey rod.

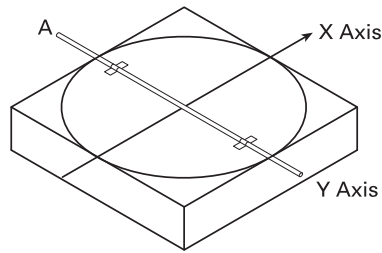

3. Enter +5.000% grade into the X-axis. When grade is entered into the X-axis, the Y-axis acts like a hinge or fulcrum.
4. With +5.000% in the X-axis, take a second reading at Point A.

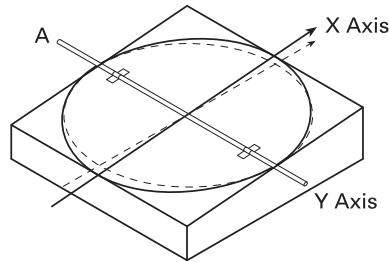

5. Alignment:
 - If the second reading is equal to the first reading, the X-axis is aligned correctly.
 - If the second reading is greater than the first reading, rotate the Zone80 DG clockwise (to the right) until the two readings are equal.
 - If the second reading is less than the first reading, rotate the Zone80 DG counter-clockwise (to the left) until the two readings are equal.



An optional sighting scope is available for the Zone80 DG which improves the axis alignment for second day setups. It is recommended that you first perform the precise alignment procedure, and then adjust the scope to these axes.

3.9

Laydown Operation

Vertical plane of laser light

You can use the Zone80 DG in laying down position to create a vertical plane for layout and alignment jobs.

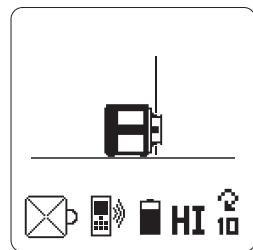

Zone80 DG Laying down screen

4

ZRC60 Remote Control

4.1

Description of the Remote Control

The RF Remote Control communicates with the Zone80 DG via RF (radio frequency) and is used to control the same functions as on the laser.

ZRC60 Remote Control

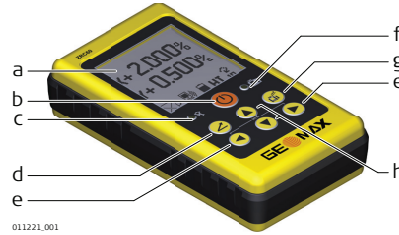

- a LCD display
- b Power button
- c Remote battery LED
- d Grade button
- e Left and right arrow buttons
- f Zone80 DG LED
- g Sleep mode button
- h Up and down arrow buttons

Description of the control panel

Components	Function
LCD display	Displays all required user information.
Power button	Press to turn on or off the remote control.
Grade button	Press to start grade entry mode.
Up and Down arrow buttons	Press to change the grade displayed. Press both simultaneously to reset the grade value to zero.
Left and Right arrow buttons	Press to display and move cursor for grade entry. Press both simultaneously to enter the Zone80 DG menu. Press and hold simultaneously for 1.5 seconds to enter the remote control menu.
Sleep mode button	Press to put the Zone80 DG in sleep mode. <ul style="list-style-type: none"> • During sleep mode, all functions are disabled. • The LCD display indicates that the Zone80 DG is in sleep mode. • The Zone80 DG sleeps for 2 hours*, then shuts down automatically and must be turned on again at the laser. • When in sleep mode, pressing the sleep button wakes the Zone80 DG and normal operation is resumed.
Zone80 DG LED	Indicates level status of the Zone80 DG.
Remote battery LED	Indicates when the batteries for the remote control should be replaced.

* In the remote control menu, you can select the sleep time.

Replacing the batteries



The remote control is powered by 2x AA batteries.

If the remote battery LED flashes, replace the batteries as shown in the picture.

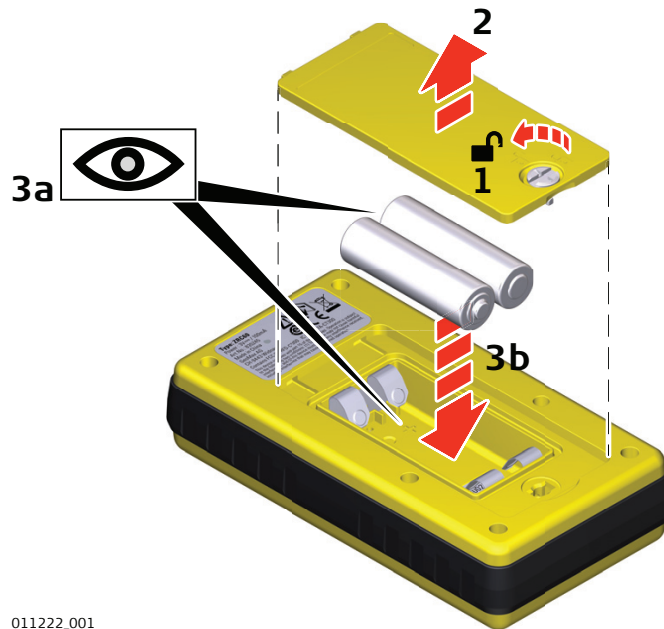

011222_001

4.2

Pairing the Zone80 DG with the ZRC60 Remote Control

Pairing step-by-step

The Zone80 DG and the ZRC60 remote control include radio devices that allow you to activate the functions on the Zone80 DG remotely up to 300 m (1000') from the Zone80 DG.

Before using the RF features, the Zone80 DG and the remote control must be paired together to be able to communicate with each other.

1. Turn off both the Zone80 DG and the remote control.
2. Press and hold the Power button on the Zone80 DG for 5 seconds to turn on the Zone80 DG in pairing mode. The Zone80 DG beeps five times slowly.
3. Press and hold the Power button on the remote control until pairing is confirmed.
4. When the pairing is successful:
Both the Zone80 DG and the remote control beep quickly five times and the Status LED flashes green quickly (5 Hz). There is no confirmation on the LCD displays during this process.
5. When the pairing is **not** successful:
Both the Zone80 DG and the remote control beep slowly three times and the Status LED flashes red (1 Hz).

4.3

Connecting Screens for the Remote Control

Information screens while connecting

There are three screens on the ZRC60 remote control which are displayed when connecting to the Zone80 DG.

Wait screen

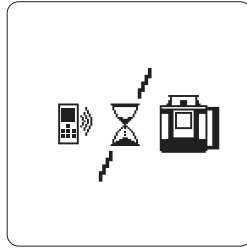

Connecting screen

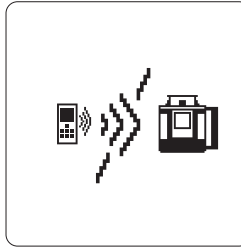

The "wait" and "connecting" screens are displayed when the remote control is first turned on and while connecting to the Zone80 DG.

Lost communication screen

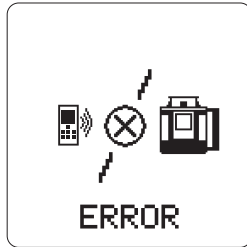

The "lost communication" screen is displayed when the Zone80 DG and the remote control have lost their communication link.



Ensure that you are within clear sight of the Zone80 DG and that you have not exceeded the working range.



The ZRC60 remote control has its own menu where you can change the display brightness, sleep mode hours and remote shut-off time. Refer to "7 ZRC60 Menu" for information on the remote control menu.

5

Receivers

5.1

Overview

Description

The Zone80 DG is sold with either the ZRP105, ZRD105 or the ZRD105B receiver. The ZRD105B receiver enhances the performance of the Zone80 DG with automatic Beam Catching and monitoring.

5.1.1

ZRP105 Receiver

Instrument components part 1 of 2



011193.001

- a Level vial
- b Audio speaker
- c LCD window
- d LEDs
- e Laser reception window
- f On-grade
- g Keypad

Component	Description
Level vial	Aids to keep the rod plumb when taking readings.
Audio Speaker	Indicates the detector's position: <ul style="list-style-type: none"> • High - Fast beeping • On-grade - Solid tone • Low - Slow beeping
LCD window	Front and rear LCD arrow indicate the detector's position.
LEDs	Display the relative position of the laser beam. Three channel indication: <ul style="list-style-type: none"> • High - Red • On-grade - Green • Low - Blue
Laser Reception window	Detects the laser beam. The reception windows must be directed towards the laser.
On-grade	Indicates the on-grade position of the laser.
Keypad	Power, accuracy and volume functions.

Instrument components part 2 of 2



011194.001

- a Bracket mounting hole
- b Offset notch
- c Product label
- d Battery door

Component	Description
Bracket mounting hole	Location to attach the receiver bracket for normal operation.
Offset notch	Use to transfer reference marks. The notch is 85 mm (3.35") below to top of the detector.
Product label	The serial number is located inside the battery compartment.
Battery door	Access to the battery compartment.

Description of the buttons



- a Power
- b Audio
- c Bandwidth

Button	Function
Power	Press once to turn on the receiver.
Audio	Press to change the audio output.
Bandwidth	Press to change detection bandwidth.

5.1.2

ZRD105, Digital Receiver

Description

The ZRD105 Digital Receiver provides you with basic position information by using an arrow display plus digital readout.

Instrument components

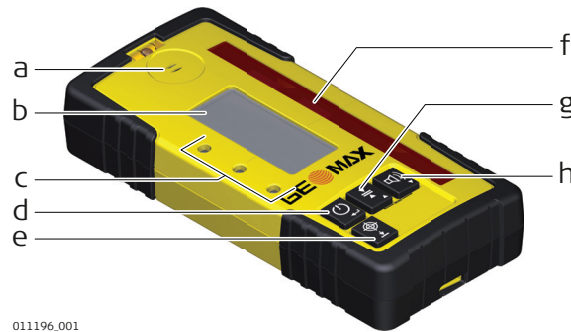

- a Speaker
- b LCD Digital Display
- c LED Display
- d Power button
- e Target button
- f Reception window
- g Bandwidth button
- h Audio button

Description of the buttons

Button	Function
Power	Press once to turn on the receiver.
	Press 1.5 seconds to turn off the receiver.
Target	Press to capture the digital reading.
Bandwidth	Press to change detection bandwidths.
Audio	Press to change the audio output.

5.1.3

ZRD105B, Digital RF Receiver

The ZRD105B receiver provides you with basic position information by using an arrow display, digital readout plus RF communication to the Zone80 DG for special features.

Instrument components

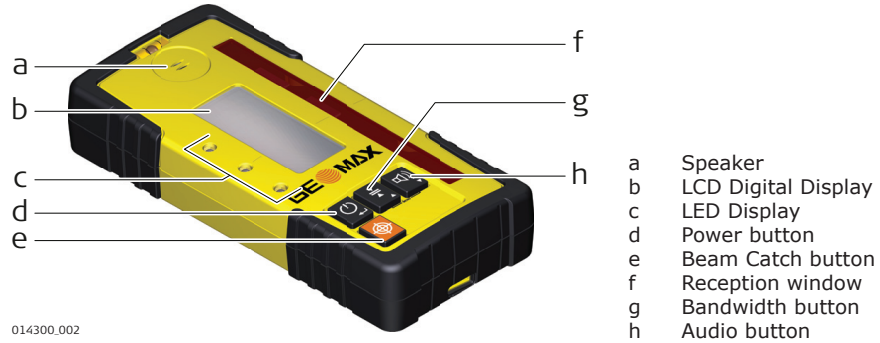

Description of the buttons

Button	Function
Power	Press once to turn on the receiver.
	Press 1.5 seconds to turn off the receiver.
Beam Catch	Press to capture the digital reading.
	Press 1.5 seconds to start the Beam Catching function. Refer to "8.4 Beam Catching (Grade Matching)".
	Press 5 seconds to start the Beam Lock function. Refer to "8.5 Beam Lock (Grade Matching and Monitoring)".
Bandwidth	Press to change detection bandwidths.
Audio	Press to change the audio output.

5.2

Using the ZRD105B Receiver with the Zone80 DG

Special functions when using ZRD105B receiver

The Zone80 DG can be used with almost any receiver.

However, when used with the ZRD105B receiver, the following special functions are available:

- Beam Catching - Allows you to match an existing grade. (Refer to "8.4 Beam Catching (Grade Matching)")
- Beam Lock - Monitors the grade position to keep it on grade. (Refer to "8.5 Beam Lock (Grade Matching and Monitoring)")

Before using the special functions, the Zone80 DG and the ZRD105B must be paired together to be able to communicate with each other. (Refer to "5.3 Pairing the ZRD105B with the Zone80 DG")

5.3

Pairing the ZRD105B with the Zone80 DG

Pairing step-by-step

The Zone80 DG and the ZRD105B Receiver include radio devices that allow you to activate the functions on the Zone80 DG remotely up to 100 m (300') from the Zone80 DG.

Before using the RF features, the Zone80 DG and the Receiver must be paired together to be able to communicate with each other.

1. Turn off the Zone80 DG.
2. Press and hold the Power Button on the Zone80 DG for 5 seconds to turn on the Zone80 DG in pairing mode. The Zone80 DG beeps five times slowly.
3. Press and hold the Power Button on the Receiver until pairing is confirmed.



When the pairing is successful:

Both the Zone80 DG and the Receiver beep five times and the LEDs are flashing (green). There is no confirmation on the LCD displays during this process.



When the pairing is **not** successful:

The Status LED on the Zone80 DG flashes (red) quickly five times.

6

Zone80 DG Menu

6.1

Access and Navigation

Description

The Zone80 DG has several menu options that allow you to optimise the performance of the Zone80 DG for an individual application.

To access the menu of the Zone80 DG, press the Left and Right arrow buttons simultaneously while the main screen is displayed.

Navigation within the menu:

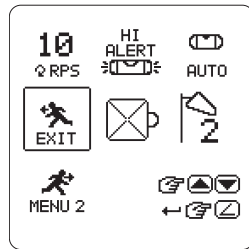

007606.001

In the bottom right-hand corner of the menu screen, there are displayed user direction buttons to indicate the navigation within the Zone80 DG menu.

Press the Up and Down arrow buttons to move the cursor and highlight an icon or an option.

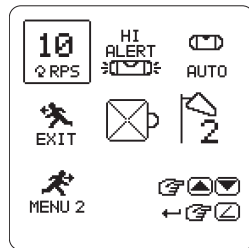

007607.001

A highlighted icon is surrounded by a box.

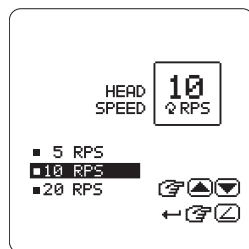

18299.001

A highlighted option is shaded in black.

Press the Grade button to select a highlighted icon or to enable/disable a highlighted option.

- If you select an icon, a screen with the options for the selected icon is displayed.
- If you select the menu icon (MENU 1, MENU 2, MENU 3), the next menu set is displayed.
- If you select the EXIT icon, the system returns to the main screen.

6.2

Menu Set 1

Overview

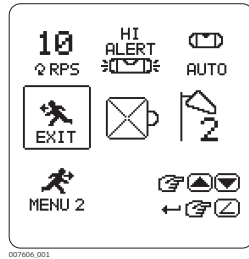

Menu Set 1

In the Menu Set 1, you can select the following parameters:

- Head Speed settings
- H.I.Alert - On/Off
- Automatic/Manual Modes
- Sensitivity settings
- Beam Masking



To exit the menu, highlight and select the EXIT icon. OR: Wait for 8 seconds and the menu is exited automatically.



To display the Menu Set 2, highlight and select the MENU 2 icon.

Head speed settings

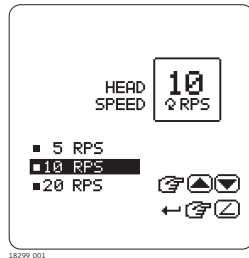

You can select three head speed settings:

- 5 rps
- 10 rps
- 20 rps

H.I.Alert - On/Off

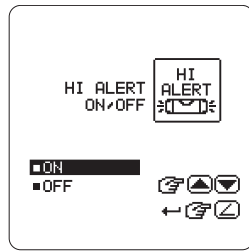

You can choose to enable or disable the H.I.Alert function:

- On
- Off

When enabled, the H.I.Alert function turns on automatically every time the Zone80 DG is turned on. The function becomes active 30 seconds after turning on the Zone80 DG.

H.I.Alert Settings

How does the H.I.Alert function work?

The Height of Instrument (H.I.) or Elevation Alert function prevents incorrect work caused by movement or settling of the tripod that would cause the laser to level at a lower height. 30 seconds after the Zone80 DG has levelled and the head of the laser starts rotating, the H.I.Alert function becomes active.

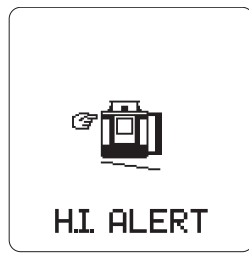

H.I.Alert screen

The H.I.Alert function monitors the movement of the laser; if disturbed, the H.I.Alert screen flashes and the Zone80 DG beeps rapidly.

To stop the alert, turn the Zone80 DG off and on again. Check the height of the laser before beginning to work again.

Automatic/Manual mode

You can select from three different modes:

- Automatic mode (default)
- Manual mode
- Manual mode with grade

You can choose to disable the automatic self-levelling mode.



The Zone80 DG always turns on in automatic mode regardless of the previous selection.

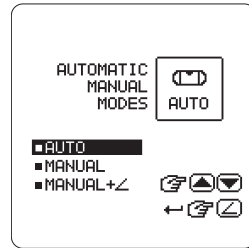

Automatic mode

The Zone80 DG always turns on in automatic mode and continuously self-levels to maintain grade accuracy.

Manual mode

In manual mode the self-levelling function is turned off. The Manual mode screen is displayed instead of the normal main screen.

The plane of laser light can be manually sloped using the same buttons as for direct grade entry, but no value for the grade is shown in the display.



Manual mode with grade

In manual mode with grade the self-levelling function is turned off. The Manual mode with grade screen is displayed instead of the normal main screen. The plane of laser light can be manually

sloped using the same buttons as for direct grade entry. The value of the entered grade is displayed in the Manual grade entry screens.

When using this mode, the Zone80 DG first levels to the selected grade, then returns to manual mode.

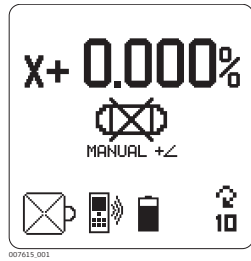

007615.001

Manual mode with grade - X-axis

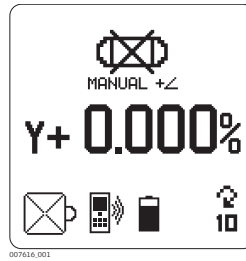

007616.001

Manual mode with grade- Y-axis

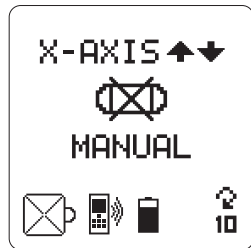

007613.001

Manual grade entry - X-axis



007614.001

Manual grade entry - Y-axis

Sensitivity settings

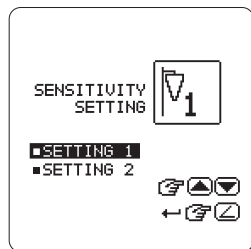

007617.001

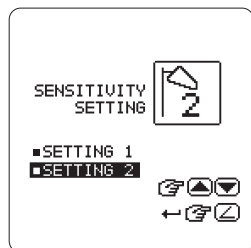

007618.001

Sensitivity Variable Screens

While levelling, the Zone80 DG responds to disturbances (wind, vibrations) and stops the head rotation, if necessary. You can choose between two levels of sensitivity:

- Sensitivity Setting 1: For normal performance - wind, vibration and other disturbances are minimal.
- Sensitivity Setting 2: For situations when wind, vibration and other disturbances are more severe.

When enabled, the H.I.Alert function turns on automatically every time the Zone80 DG is turned on. The function becomes active 30 seconds after turning on the Zone80 DG.

Beam masking

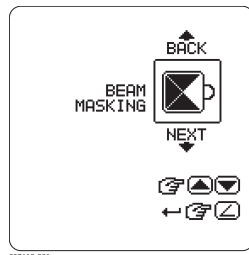

007619.001

Beam masking Screen

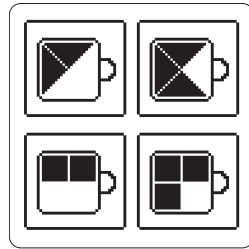

007620.001

Possible combinations

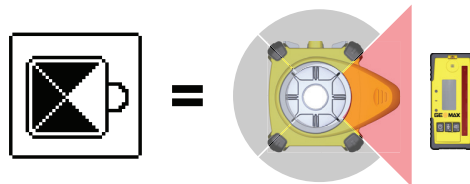

011231.001

Beam masking allows you to turn off the laser beam on selected sides of the laser to prevent interference with other lasers or receivers that could be working in the same working area.

You can choose to block half or three quarters of the rotating laser beam.

Each of the four displayed combinations is available in four different variants. The dark area represents the area where the laser beam is turned off.

Use the Up or Down arrow buttons to choose from the 16 possible combinations.

6.3

Menu Set 2

Overview

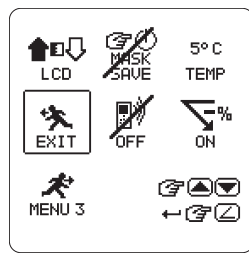

007621.001

Menu Set 2

In the Menu Set 2, you can select the following parameters:

- Display brightness
- Beam masking - save at power off
- Temperature sensitivity
- Negative grade - enable/disable
- Radio - enable/disable



To exit the menu, highlight and select the EXIT icon. OR: Wait for 8 seconds and the menu is exited automatically.



To display the Menu Set 3, highlight and select the MENU 3 icon.

Display brightness

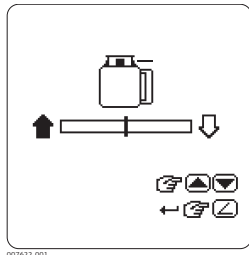

Display brightness screen

With this setting, you can change the display brightness. Use the Up and Down arrow buttons to adjust the brightness as desired.

Save beam masking at power off

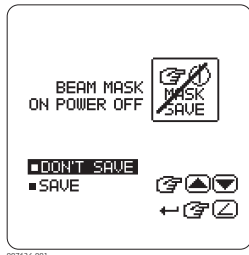
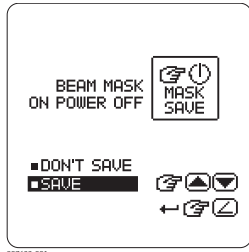

Save beam masking screens

Normally, the beam masking setting is disabled every time you turn off the Zone80 DG. If you prefer to save the beam masking settings for usage on the following day, you can enable the saving of the beam masking setting:

- Save: The beam masking settings are saved at power off.
- Do not save: The beam masking settings are disabled at power off.

Temperature sensitivity settings

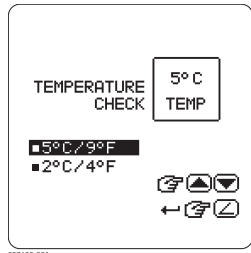

For each change in temperature of $\pm 5\text{ }^{\circ}\text{C}$ ($\pm 9\text{ }^{\circ}\text{F}$) the Zone80 DG returns to the level position to check if the change in temperature has led to a change of the main levelling system. For a more sensitive unit, you can change the setting to $\pm 2\text{ }^{\circ}\text{C}$ ($\pm 4\text{ }^{\circ}\text{F}$) temperature change.

Available intervals:

- Temperature is checked every 5 $^{\circ}\text{C}/9\text{ }^{\circ}\text{F}$
- Temperature is checked every 2 $^{\circ}\text{C}/4\text{ }^{\circ}\text{F}$

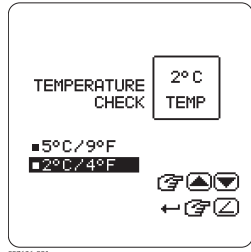

Temperature check settings screens

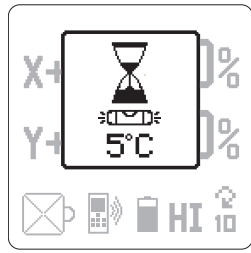

Relevelling process

When the Zone80 DG is relevelling, the Temperature check wait screen is displayed. Wait until the process is finished before using the laser again. The Status LED flashes to indicate normal levelling.

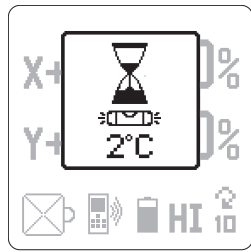

Temperature check wait screens

Negative grade - enable/disable

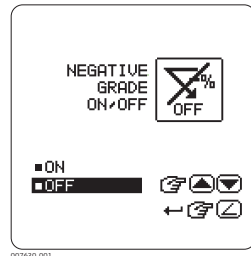
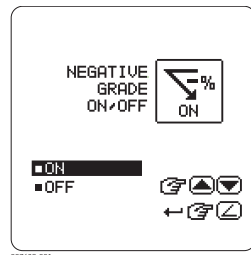

Negative grade screens

If you want to prevent confusion when setting up the laser, you can disable the negative grade function on the Zone80 DG.

- ON: Negative grade is enabled.
 - OFF: Negative grade is disabled.
- When negative grade is disabled, only positive grade can be entered in the direction of the arrow-shaped alignment marks on the top of the Zone80 DG.

Radio - enable/disable

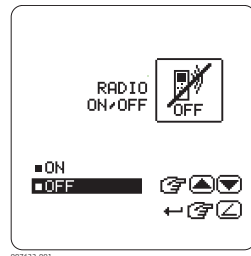
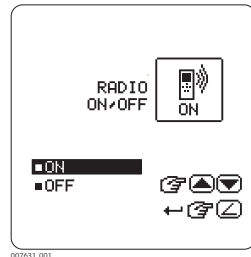

Radio screens

To be able to communicate with the ZRC60 remote control and the receiver, the radio on the Zone80 DG must be enabled. The radio is automatically enabled when the units are paired together.

- ON: Radio is enabled.
- OFF: Radio is disabled.



If you do not use the remote control or the receiver, it is recommended to disable radio in order to save battery life.

6.4

Menu Set 3

Overview

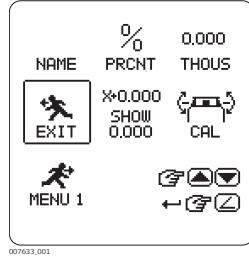

Menu Set 3

In the Menu Set 3, you can select the following parameters:

- Customer name entry
- Display - percent/per mil
- Display - thousandths/hundredths
- Show grade settings on power up
- Calibration alert - enable/disable



To exit the menu, highlight and select the EXIT icon. OR: Wait for 8 seconds and the menu is exited automatically.



To display the Menu Set 1, highlight and select the MENU 1 icon.

Customer name settings

The Customer name settings allow you to enter the name of the customer, to enable/disable the customer name screen when turning on the Zone80 DG, and to protect the name entry with a password.

Customer name entry

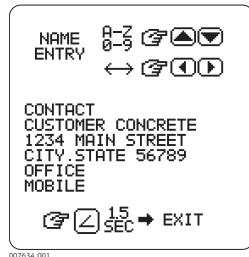

Customer name entry screen

When entering the Customer Name settings the first time, you are taken directly to the Customer Name entry screen. On this screen, you can enter 6 lines of text with up to 20 characters per line.

It is recommended to determine the desired text before changing or entering the information:

To save the entered information, press and hold the Grade button for 1.5 seconds.

Enable/disable the display name on start-up

After saving the name entry, the display name on start-up screen is displayed. You can choose between two options:

- Display (YES): The customer name screen is displayed each time the laser is turned on.
- Save only (NO): The information entered in the customer name screen is stored in the laser, but is only visible when the customer name entry screen is accessed.

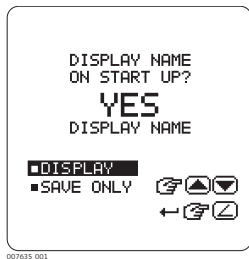

007635.001



007636.001

Display name on start-up screens

Protect customer name entry with a password

After selecting the display on start-up setting, you can choose to enable/disable the password protection of the customer name entry screen:

- YES: Password protection is enabled. Enter a four-digit password. The password is required each time you access the customer name entry screen.
- NO: Password protection is disabled.



007637.001



007638.001

New password screens

Display - percent/per mil

You can choose to display the grade in percent of grade or per mil:

- 1.000% = 1 metre rise per 100 metres
- 1.00‰ = 1 metre rise per 1000 metres

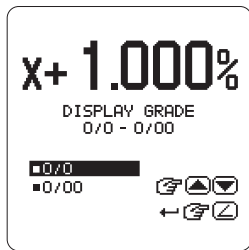

007639.001

Display percent

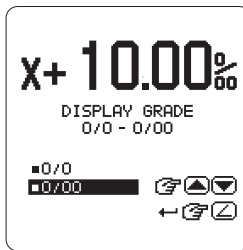

007640.001

Display per mil

Standard usage is percent of grade.

You are asked to confirm the selected option to prevent unwanted changes and possible errors due to the shift of the decimal point.

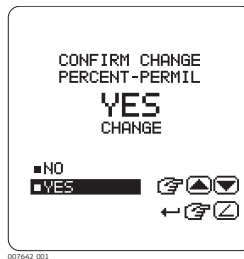
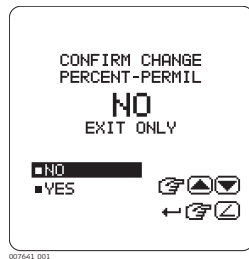

Per mil - confirmation Screens

Display - thousandths or hundredths

You can choose to display percent of grade in thousandths or hundredths:

- 1.000 - Standard usage is to display thousandths or three digits after the decimal point.
- 1.00 - If you choose to display hundredths, only two digits are displayed after the decimal point.

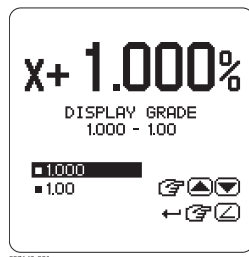

007643_001

Display thousandths

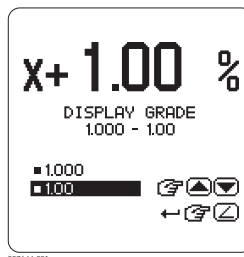

007644_001

Display hundredths

Show grade settings on power up

Normally, the grade value is reset to 0.000% every time you turn on the Zone80 DG. If you prefer to display the previous grade settings when turning on the Zone80 DG, you can enable the option **Show Grade**.

- Show 0.000: The grade settings are reset to 0.000% on power up (default).
- Show Grade: The previous grade settings are displayed on power up.

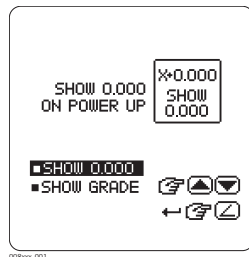

008xxx_001

Show 0.000%

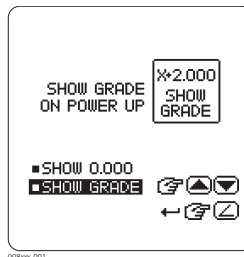

008xxx_001

Show Grade



Note: When the option **Show 0.000%** is selected and you want to restore the last set grade(s), press and hold the Grade button for 1.5 seconds.

Calibration alert activation

Enabling/disabling the calibration alert function

You can choose to enable/disable a calibration alert function based on hours of use:

- ON: Calibration alert is enabled
- OFF: Calibration alert is disabled

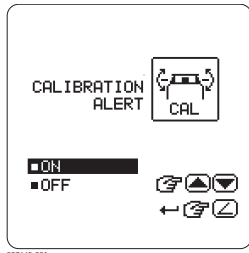

007645.001

Enable calibration alert screen

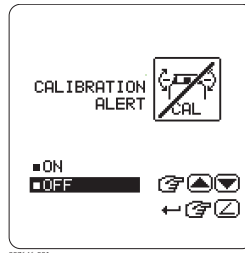

007646.001

Disable calibration alert screen

Setting the hours for calibration alert

If you enabled the calibration alert function, the "Set Calibration Alert Hours" screen is displayed. The default setting is 1.040 hours, which corresponds to approximately 6 months, based on a 40-hour working week.



007647.001

Set calibration alert hours screen

Set the number of hours you would like to work before receiving a calibration alert. The hours can be set in increments of 40 hours.

Display of calibration alert on start-up screen

If you enabled the calibration alert function, the calibration alert hours are displayed on the start-up screen after turning on the Zone80 DG:

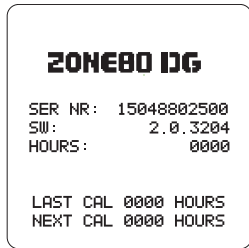

18300.001

Calibration alert hours on start-up screen

- LAST CAL: The number of hours since the last calibration.
- NEXT CAL: The number of hours remaining until the next calibration is planned.

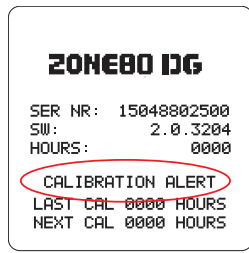

Calibration alert flashing screen

When the number of planned hours is reached, the words "CALIBRATION ALERT" are displayed for 8 seconds.

After calibrating the Zone80 DG, the calibration alert hours are automatically reset. Changing or disabling the calibration alert is only possible by accessing the menu option "Calibration alert activation".

7

ZRC60 Menu

Overview



007690_001

Remote control menu screen

The ZRC60 remote control has its own menu where you can change the following parameters:

- Display brightness
- Sleep mode hours
- Remote shut-off time



To access the remote control menu, press and hold the Left and Right arrow buttons on the remote control for 1.5 seconds.



For navigation within the remote control menu, use the same buttons as for navigation within the Zone80 DG menu. Refer to "6.1 Access and Navigation".

Display brightness

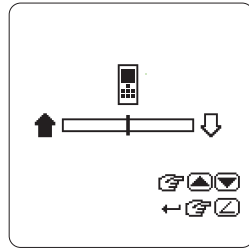

007691_001

Remote control display brightness

You can change the display brightness on this screen.

Use the Up and Down arrow buttons to adjust the brightness as desired.

Sleep mode hours



007692_001

Sleep mode hours

You can determine how long the Zone80 DG stays in sleep mode before turning off completely:

- 2 hours
- 4 hours
- 8 hours
- 16 hours

Remote shut-off time

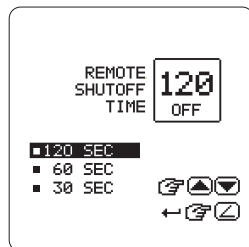

007693_001

Shut-off time

You can determine a shut-off time for the remote control:

- 30 seconds
- 60 seconds
- 120 seconds

If the remote control is not used during this time, it shuts off automatically.

8 Applications

8.1 Agriculture levelling

Agriculture levelling step-by-step

Application shown using the GeoMax ZEN10 receiver.

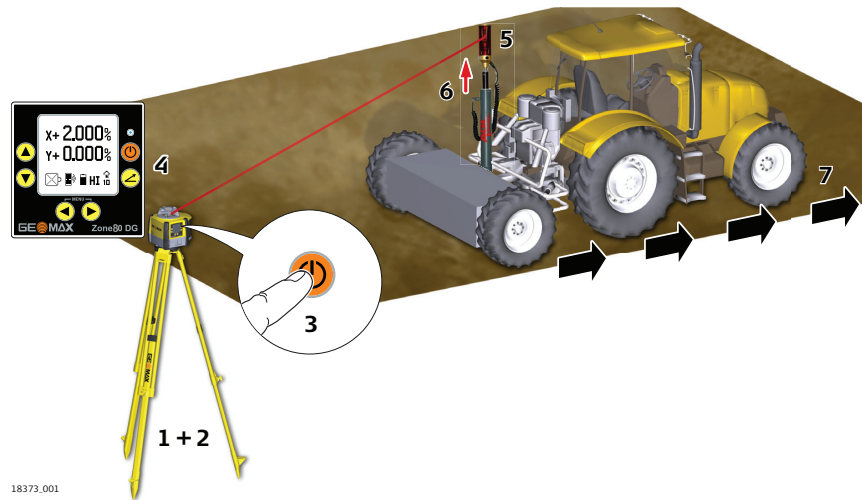

1. Set up the Zone80 DG on a tripod.
2. Set up the tripod on a stable surface outside the working area.
3. Turn on the Zone80 DG.
4. Enter the required grade on the Zone80 DG. Refer to "3.4 Grade Entry".
5. Attach the receiver on the mast that is mounted on the machine.
6. Raise the mast until receiver is on grade with the reference line.
☞ The laser beam of the Zone80 DG acts as a constant grade reference.
7. Level the ground according to the grade reference.

8.2 Checking Grades

Checking grades step-by-step

Application shown using the ZRP105 receiver.

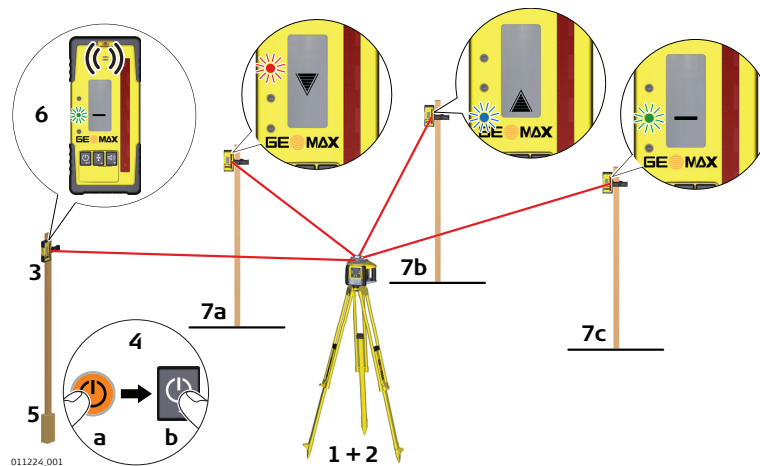



1. Set up the Zone80 DG on a tripod.
2. Set up the tripod on a stable surface outside the working area.
3. Attach the receiver to a rod.
4. Turn on the Zone80 DG and the receiver.
5. Set the base of the rod on a known point for the finished grade.
6. Adjust the height of the receiver on the rod until the on-grade (centre-line) position is indicated on the receiver by:
 - the centre bar,
 - the green flashing LED,
 - a solid audio tone.
7. Set the rod with the attached receiver on top of the excavation or concrete pour to check for correct elevation.
8. Variances can be read in precise measurements with the digital receiver.
 - 7a: Position is too high.
 - 7b: Position is too low.
 - 7c: Position is on grade.

8.3

Entering Grades

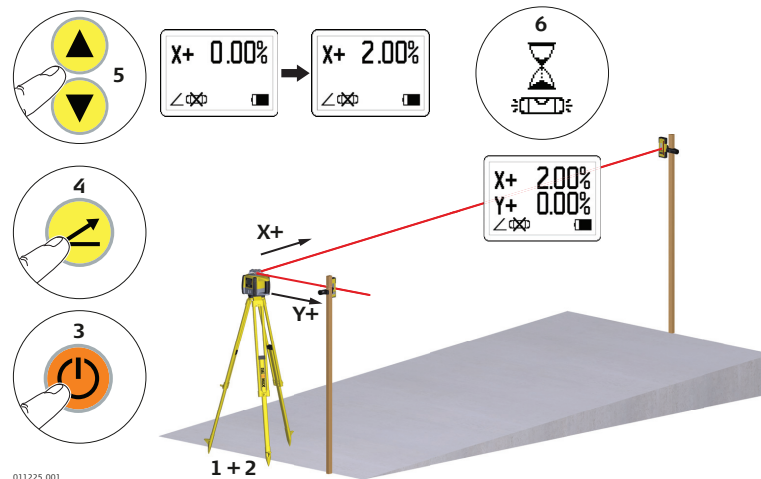
Entering grades step-by-step



1. Set up the Zone80 DG on a tripod.
 2. Set up the tripod at the base of the slope with the X-axis pointing in the direction of the slope.
 3. Turn on the Zone80 DG.
 4. Press the Grade button.
 5. Press the Up or Down button to enter grade for the X-axis (single slope). Press the Grade button to enter grade for the Y-axis. Press the Grade button again to exit grade entry mode.
 6. Once grade is entered, the Zone80 DG will begin to adjust to grade. Do not disturb the Zone80 DG during this process.
-  To restore previous grade, press and hold the Grade button for 1.5 seconds.

8.4

Beam Catching (Grade Matching)

Beam Catching using the ZRD105B step-by-step

Using the Beam Catching feature you can match an existing grade. The Zone80 DG moves to the new grade position, displays the grade found and begins self-levelling to maintain the grade over time. Maximum range is 100 m (300').

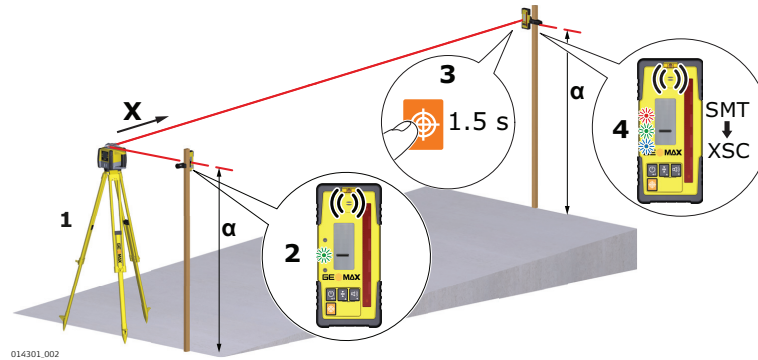

1. The Beam Catching process can only be run on the X-axis in horizontal mode.
2. Set up the Zone80 DG at the base of a slope with no grade dialled into the Zone80 DG and with the X-axis pointing in the direction of the slope.
3. Adjust the height of the receiver on the rod at the base of the slope until the on-grade (centreline) position is indicated on the receiver by:
 - the centre bar,
 - the green flashing LED,
 - a solid audio tone,
 - the digital display.
4. Move the rod with the receiver to the top of the slope. To start the Beam Catching process, press the Beam Catch button for 1.5 seconds.
 - The Zone80 DG searches for the receiver until the on-grade position is found. The receiver shows **SMT**, then **XSC** while catching the beam on the X-axis.
 - Once the on-grade position is found, the receiver flashes all three LEDs simultaneously one time and the receiver returns to normal operation.
5. After this signal, the receiver can be moved and used as normal. The grade for the sloped axis is displayed on the LCD display and the Zone80 DG now self-levels to this new slope.

8.5

Beam Lock (Grade Matching and Monitoring)

Beam Lock using the ZRD105B step-by-step

Using the Beam Lock feature, you can match an existing grade and monitor the laser beam. The Zone80 DG moves to the new grade position, displays the grade found and begins self-levelling to maintain the grade over time. The ZRD105B must remain in place to monitor any movements of the rotating beam. Thus, an accurate grade setup is maintained. Maximum range is 100 m (300').

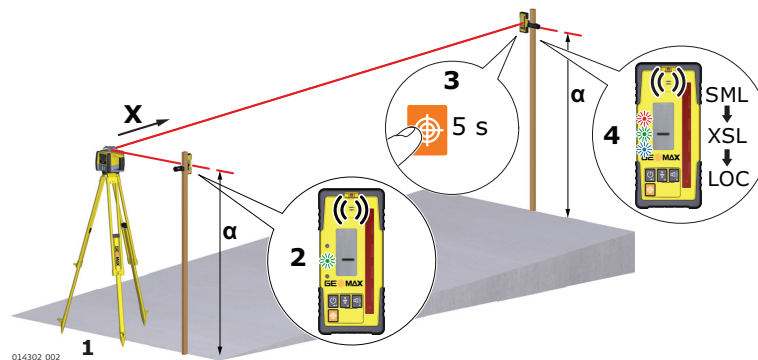

1. The Beam Lock process can only be run on the X-axis in horizontal mode.

 2. Ensure that the grade value is set to zero.
Set up the Zone80 DG at the base of a slope with the X-axis pointing in the direction of the slope.

 3. At the base of the slope, adjust the height of the ZRD105B receiver on the rod until the on-grade (centreline) position is indicated on the receiver by:
 - the centre bar,
 - the green flashing LED,
 - a solid audio tone,
 - the digital display.

 4. Move the rod with the receiver to the top of the slope. To start the Beam Lock process, press the Beam Catch button for 5 seconds.
 - The Zone80 DG searches for the receiver until the on-grade position is found. The receiver shows **SML**, then **XSL** while catching and locking the beam on the X-axis.
 - Once the on-grade position is found, the receiver flashes all three LEDs simultaneously one time.
 - The display shows **LOC** while the receiver is in lock mode.

 5. After this signal, the receiver must remain in place to monitor any movements of the rotating beam. The grade for the sloped axis is displayed on the LCD display of the Zone80 DG.

 6. To turn off the Beam Lock mode on the receiver, hold the Power button for 1.5 seconds.

 7. To lock and monitor the rotating beam of an existing grade, mount the receiver in the plane of the laser before starting the Beam Lock process.
-

9

Batteries

Description

The Zone80 DG can be purchased with a rechargeable Li-Ion battery pack.

The following information is appropriate only to the model you have purchased.

9.1

Operating Principles

First-time use/ charging batteries

- The battery must be charged before using it for the first time because it is delivered with an energy content as low as possible.
- The permissible temperature range for charging is from 0 °C to +40 °C/+32 °F to +104 °F. For optimal charging, we recommend charging the batteries at a low ambient temperature of +10 °C to +20 °C/+50 °F to +68 °F if possible.
- It is normal for the battery to become warm during charging. Using the chargers recommended by GeoMax, it is not possible to charge the battery once the temperature is too high.
- For new batteries or batteries that have been stored for a long time (> three months), it is effectual to make only one charge/discharge cycle.
- For Li-Ion batteries, a single discharging and charging cycle is sufficient. We recommend carrying out the process when the battery capacity indicated on the charger or on a GeoMax product deviates significantly from the actual battery capacity available.

Operation/ discharging

- The batteries can be operated from -20 °C to +55 °C/-4 °F to +131 °F.
- Low operating temperatures reduce the capacity that can be drawn; high operating temperatures reduce the service life of the battery.

9.2

Battery for Zone80 DG

Charging the Li-Ion battery pack step-by-step

The rechargeable Li-Ion battery pack on the Zone80 DG can be charged without removing the battery pack from the laser.



1. Slide the locking mechanism on the battery compartment to the centre position to expose the charge jack.
 2. Plug the AC connector into the appropriate AC power source.
 3. Connect the charger plug into the charge jack on the Zone80 DG battery pack.
 4. The small LED next to the charge jack flashes indicating that the Zone80 DG is charging. The LED is on solid when the battery pack is fully charged.
 5. When the battery pack is fully charged, disconnect the charger plug from the charge jack.
 6. Slide the locking mechanism to the left position to prevent dirt from getting into the charging jack.
-  The battery pack reaches a full charge in approximately 5 hours if completely empty. A one-hour charge should allow the Zone80 DG to run for a full 8 hours.

Changing the Li-Ion battery pack step-by-step

With the rechargeable Li-Ion battery pack the battery indicator on the Zone80 DG LCD display shows when the battery pack is low and needs to be charged. The charge indicator LED on the Li-

Ion battery pack indicates when the pack is being charged (flashing slowly) or fully charged (on, not flashing).

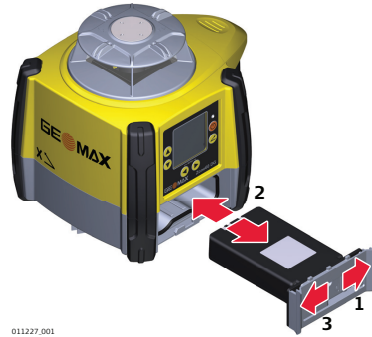

1. The batteries are inserted in the front of the laser.
2. The rechargeable battery pack can be recharged without being removed from the laser. Refer to " Charging the Li-Ion battery packstep-by-step" for further information.
3. Slide the locking mechanism on the battery compartment to the right and open the cover of the battery compartment.
4. Remove the batteries from the battery compartment and/or insert the batteries into the battery compartment.
5. Close the cover of the battery compartment and slide the locking mechanism to the left until it locks into position.

10

Accuracy Adjustment

About

- It is the responsibility of the user to follow operating instructions and to periodically check the accuracy of the laser and work as it progresses.
- The Zone80 DG is adjusted to the defined accuracy specification at the factory. It is recommended to check the laser for accuracy upon receipt and periodically thereafter to ensure accuracy is maintained. If the laser requires adjustment, contact your nearest authorised service centre or adjust the laser using the procedures described in this chapter.
- Only enter the accuracy adjustment mode when you plan to change the accuracy. Accuracy adjustments should only be performed by a qualified individual that understands basic adjustment principles.
- It is recommended to perform this procedure with two people on a relatively flat surface.

10.1

Checking the Level Accuracy

Checking the level accuracy step-by-step



The Zone80 DG is within its accuracy specification if the four marks are within ± 1.5 mm ($\pm 1/16$ ") from the centre.

1. Place the Zone80 DG on a flat, level surface or tripod approximately 30 m (100 ft) from a wall.

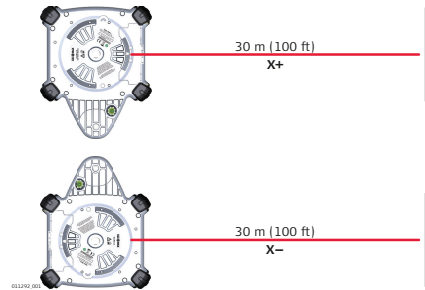

2. Align the first axis so that it is square to a wall. Allow the Zone80 DG to self-level completely (approximately 1 minute after the Zone80 DG begins to rotate).
3. Mark the position of the beam.
4. Rotate the laser 180° and allow it to self-level.
5. Mark the opposite side of the first axis.

6. Align the second axis of the Zone80 DG by rotating it 90° so that this axis is square to the wall. Allow the Zone80 DG to self-level completely.

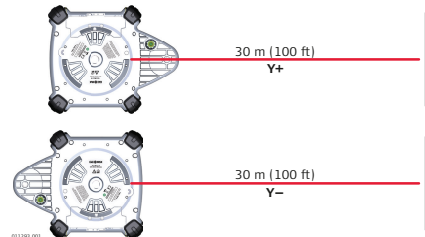

7. Mark the position of the beam.
8. Rotate the laser 180° and allow it to self-level.
9. Mark the opposite side of the second axis.

10.2

Adjusting the Self-Levelling Accuracy

Description

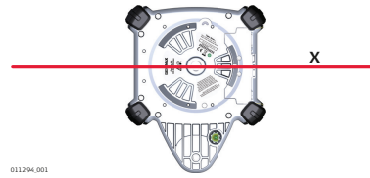

In Adjustment Mode the X-axis LED indicates changes to the X-axis.

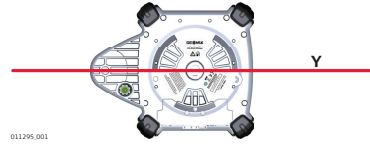

The Y-axis LED indicates changes to the Y-axis.

Entering calibration mode step-by-step

1. Turn off the power.
2. Put the Zone80 DG in an upright position.
3. Press and hold both the Up and Down arrow buttons.
4. Press the Power button. The X-axis calibration screen appears. The Zone80 DG is now in calibration mode.



In calibration mode, the LED does not blink and the laser head continues to rotate. An hour-glass indicates that the Zone80 DG is levelling.

Calibrating the X-axis step-by-step

When entering Calibration mode, the X-axis calibration screen appears:

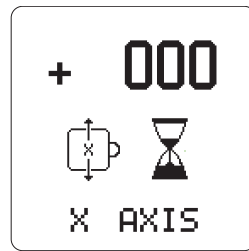

1. When the hour glass has disappeared, indicating that the Zone80 DG has levelled, check both sides of the X-axis.
2. Press the Up and Down arrow buttons to bring the plane of laser light to the specified level position.



Each step represents approximately 2 arc seconds of change. Therefore, 5 steps equal approximately 1.5 mm at 30 m (1/16" at 100').

3. Press the Grade button to accept the adjusted position and to switch to the Y-axis calibration screen.

Calibrating the Y-axis step-by-step

After calibration of the X-axis, the Y-axis calibration screen appears:

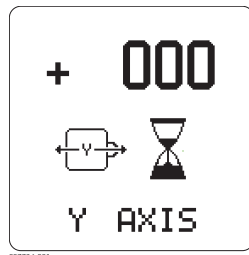

1. When the hour glass has disappeared, indicating that the Zone80 DG has levelled, check both sides of the Y-axis.

2. Press the Up and Down arrow buttons to bring the plane of laser light to the specified level position.

-  Each step represents approximately 2 arc seconds of change. Therefore, 5 steps equal approximately 1.5 mm at 30 m (1/16" at 100').

3. Press the Grade button to accept the adjusted position and to switch to the X-axis calibration screen.

4. Press and hold the Grade button for 3 seconds to accept the adjusted positions, save and store the calibration settings and return to the Main user screen.

Exiting calibration mode

Press and hold the Grade button for 3 seconds to save and exit Calibration mode.



Pressing the Power button at any time while in Calibration mode will exit the mode without saving changes.

10.3

Adjusting the Vertical Accuracy

Entering calibration mode for the Z-axis step-by-step

1. Turn off the power.

2. Put the Zone80 DG in laydown position.

3. With power off, press and hold both the Up and Down arrow buttons.

4. Press the Power button. The active axis is the Z-axis.

-  In Calibration mode, the LED does not blink and the laser head continues to rotate. An hour-glass indicates that the Zone80 DG is levelling.

Calibrating the Z-axis step-by-step

When entering calibration mode for the Z-axis, the Z-axis calibration screen appears:

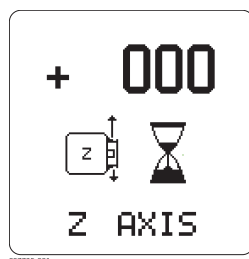





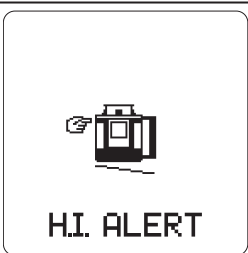
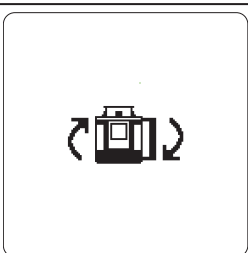
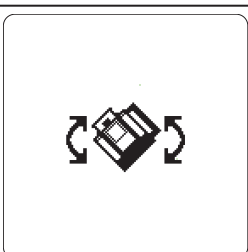
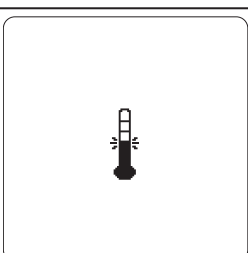
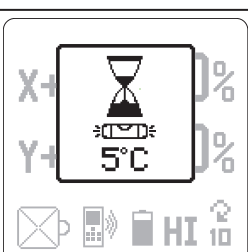

1. Press the Up and Down arrow buttons to increment the vertical position of the laser beam.

2. Continue to press the Left and Right arrow buttons and monitor the beam until the Zone80 DG is within its specified range.

3. Press and hold the Grade button for 3 seconds to accept the adjusted position, to save and store the calibration settings and to return to the main user screen.
-

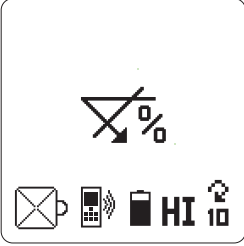
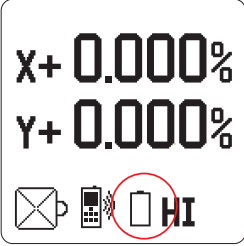
Alerts and message Screens

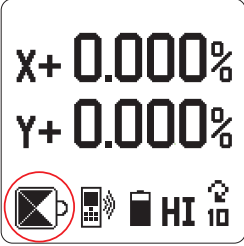
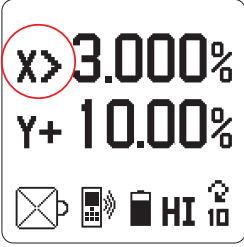
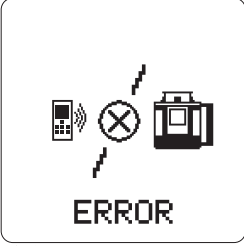
Alert	Symptom	Possible causes and solutions
 <p>007746_001</p>	<p>Low Battery indication on the display.</p>	<p>The batteries are low. Recharge the Li-Ion battery pack. Refer to "9 Batteries".</p>
 <p>007610_001</p>	<p>Elevation (H.I.) Alert The Elevation (H.I.) Alert screen is shown and the audio beeps. (Level position)</p>	<p>The Zone80 DG has been bumped or tripod was moved. Turn off Zone80 DG to stop alert, check the height of the laser before beginning to work again. Allow Zone80 DG to relevel and check the height of the laser. After 2 minutes in the alert condition, the unit will shut off automatically.</p>
 <p>007747_001</p>	<p>Servo Limit Alert The Servo Limit Alert screen is shown.</p>	<p>The Zone80 DG is tipped too far to reach a level position. Relevel the Zone80 DG within the 6 degree self-levelling range. After 2 minutes in the alert condition, the unit will shut off automatically.</p>
 <p>007748_001</p>	<p>Tilt Alert The Tilt Alert screen is shown.</p>	<p>The Zone80 DG is tipped more than 45° from level. After 2 minutes in the alert condition, the unit will shut off automatically.</p>
 <p>007749_001</p>	<p>Temperature Alert The Temperature Alert screen is shown.</p>	<p>The Zone80 DG is in an environment where it cannot operate without damaging the laser diode, for example being exposed to the heat from direct sunlight. Shade the Zone80 DG from the sun. After 2 minutes in the alert condition, the unit will shut off automatically.</p>
 <p>007627_001</p>	<p>Temperature Check The Temperature Check Alert screen is shown.</p>	<p>The Zone80 DG has detected a change in temperature of 5°C and is checking the level position.</p> <p> Wait until procedure is complete. Refer to "Temperature sensitivity settings" for changing the setting between 5°C and 2°C.</p>

Alert	Symptom	Possible causes and solutions
 <p>007750.001</p>	Negative grade entry is not possible.	The negative grade function is disabled. Only positive grade can be entered in the Zone80 DG. To enter negative grade, enable the negative grade function. Refer to " Negative grade - enable/disable".
 <p>007751.001</p>	The "empty battery" icon flashes.	The Zone80 DG has reached a low battery condition and changes the head speed to 7rps. If the receiver detects the Zone80 DG rotating at 7 rps, it displays a small flashing Zone80 DG.  Check the battery of the Zone80 DG.
 <p>007752.001</p>	The beam is not emitting from all sides of the laser.	Beam masking is activated for two or more sides of the laser. To de-activate or change beam masking, refer to " Beam masking".
 <p>007753.001</p>	It is not possible to enter grade greater than 10.00% or 3.000%.	The Zone80 DG allows for up to 10% grade entry in both axes simultaneously. If the grade entry for one axis is greater than 10%, the cross axis is limited to 3%.
 <p>007600.001</p>	The Zone80 DG is not communicating with the remote control.	The Zone80 DG has lost the communication link to the remote control.  Ensure that you are within clear sight of the Zone80 DG and that you have not exceeded the 100 m (300') working range.

Troubleshooting

Problem	Possible Causes	Suggested Solutions
The Zone80 DG does not turn on.	The batteries are low or dead.	Check the batteries and change or charge the batteries if necessary. If the problem continues, return the Zone80 DG to an authorised service centre for service.

Problem	Possible Causes	Suggested Solutions
The distance of the laser is reduced.	Dirt is reducing the laser output.	Clean the windows of the Zone80 DG and the receiver. If the problem continues, return the Zone80 DG to an authorised service centre for service.
The laser receiver is not working properly.	The Zone80 DG is not rotating. It may be leveling or in H.I.Alert.	Check for proper operation of the Zone80 DG.  Refer to the receiver manual for more information.
	The receiver is out of usable range.	Move closer to the Zone80 DG.
	The batteries of the receiver are low.	Check the low battery symbol on the receiver display. Change the receiver batteries.
The ZRC60 remote control is not working properly.	The remote control is out of usable range.	For normal operation, the remote control works up to 300 m (1,000').
	The batteries of the remote are low.	Check the Remote Battery LED on the control panel. Change the remote control batteries.
The display is too dark or too light.	The setting of the display brightness is unsuitable.	The brightness for both the Zone80 DG and the remote control can be reset in the menu of the respective device. Refer to " Display brightness"(Zone80 DG) or to " Display brightness"(Remote control).
The grade is shown in percent(%) or per mil (‰).	The wrong setting has been selected.	Choose the desired setting in the option menu. (" Display - percent/per mil")
The grade resets to zero each time the laser is turned on.	The wrong setting has been selected.	Choose the desired setting in the option menu. (" Show grade settings on power up")
The laser stops too often to relevel.	The sensitivity setting may be set to the "fine" setting (Setting 1).	Choose the Sensitivity Setting 2 in the option menu. (" Sensitivity settings")
	The Tripod may be unstable.	Check your tripod for stability. Tighten all screws. Use sand bags on the legs if necessary.
	The wind is causing the Zone80 DG to move too much.	Shelter the Zone80 DG from the wind. Press the tripod legs more firmly into the ground.

12

Care and Transport

12.1

Transport

Transport in the field

When transporting the equipment in the field, always make sure that you

- either carry the product in its original container,
 - or carry the tripod with its legs splayed across your shoulder, keeping the attached product upright.
-

Transport in a road vehicle

Never carry the product loose in a road vehicle, as it can be affected by shock and vibration. Always carry the product in its container and secure it.

For products for which no container is available use the original packaging or its equivalent.

Shipping

When transporting the product by rail, air or sea, always use the complete original GeoMax packaging, container and cardboard box, or its equivalent, to protect against shock and vibration.

Shipping, transport of batteries

When transporting or shipping batteries, the person responsible for the product must ensure that the applicable national and international rules and regulations are observed. Before transportation or shipping, contact your local passenger or freight transport company.

Field adjustment

Exposing the product to high mechanical forces, for example through frequent transport or rough handling, or storing the product for a long time may cause deviations and a decrease in the measurement accuracy. Periodically carry out test measurements and perform the field adjustments indicated in the User Manual before using the product.

12.2

Storage

Product

Respect the temperature limits when storing the equipment, particularly in summer if the equipment is inside a vehicle. Refer to "13 Technical Data" for information about temperature limits.

Li-Ion and alkaline batteries

For Li-Ion and alkaline batteries

- Refer to "Technical Data" for information about storage temperature range.
- Remove batteries from the product and the charger before storing.
- After storage recharge batteries before using.
- Protect batteries from damp and wetness. Wet or damp batteries must be dried before storing or use.

For Li-Ion batteries

- A storage temperature range of 0 °C to +30 °C / +32 °F to +86 °F in a dry environment is recommended to minimize self-discharging of the battery.
 - At the recommended storage temperature range, batteries containing a 40% to 50% charge can be stored for up to one year. After this storage period the batteries must be recharged.
-

12.3

Cleaning and Drying

Product and accessories

- Blow dust off lenses and prisms.
 - Never touch the glass with your fingers.
 - Use only a clean, soft, lint-free cloth for cleaning. If necessary, moisten the cloth with water or pure alcohol. Do not use other liquids; these may attack the polymer components.
-

Damp products

Dry the product, the transport container, the foam inserts and the accessories at a temperature not greater than 40°C /104°F and clean them. Remove the battery cover and dry the battery compartment. Do not repack until everything is completely dry. Always close the transport container when using in the field.

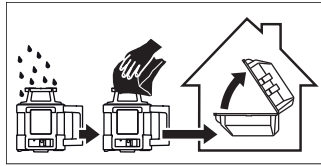

Cables and plugs

Keep plugs clean and dry. Blow away any dirt lodged in the plugs of the connecting cables.

13

Technical Data

13.1

Conformity to National Regulations

Conformity to national regulations

- FCC Part 15 (applicable in US)
- Hereby, GeoMax AG declares that the radio equipment type Zone80 DG is in compliance with Directive 2014/53/EU and other applicable European Directives. The full text of the EU declaration of conformity is available at the following Internet address: <http://www.geomax-positioning.com/Downloads.htm>.



Class 1 equipment according to European Directive 2014/53/EU (RED) can be placed on the market and be put into service without restrictions in any EEA member state.

- The conformity for countries with other national regulations not covered by the FCC part 15 or European Directive 2014/53/EU has to be approved prior to use and operation.
- Japanese Radio Law.
 - This device is granted pursuant to the Japanese Radio Law (電波法).
 - This device should not be modified (otherwise the granted designation number will become invalid).

Frequency band

2400 - 2483.5 MHz

Output power

< 100 mW (e. i. r. p.)

Antenna

Zone80 DG:	Chip antenna
ZRC60 remote control:	Chip antenna

13.2

Dangerous Goods Regulations

Dangerous Goods Regulations

The products of GeoMax are powered by Lithium batteries.

Lithium batteries can be dangerous under certain conditions and can pose a safety hazard. In certain conditions, Lithium batteries can overheat and ignite.



When carrying or shipping your GeoMax product with Lithium batteries onboard a commercial aircraft, you must do so in accordance with the **IATA Dangerous Goods Regulations**.



GeoMax has developed **Guidelines** on "How to carry GeoMax products" and "How to ship GeoMax products" with Lithium batteries. Before any transportation of a GeoMax product, we ask you to consult these guidelines on our web page (<http://www.geomax-positioning.com/dgr>) to ensure that you are in accordance with the IATA Dangerous Goods Regulations and that the GeoMax products can be transported correctly.



Damaged or defective batteries are prohibited from being carried or transported onboard any aircraft. Therefore, ensure that the condition of any battery is safe for transportation.

13.3

General Technical Data of the Product

Operating range

Operating range (diameter):

Zone80 DG:	1100 m/3600 ft
------------	----------------

Self-levelling accuracy

Type	Value
Self-levelling accuracy	±1.5 mm at 30 m (±1/16" at 100 ft)

Self-levelling accuracy is defined at 25 °C (77 °F).

Self-levelling range

Type	Value
Self-levelling range	±6°

Head speed

Type	Value
Head speed	5, 10, 20 rps

Laser dimensions

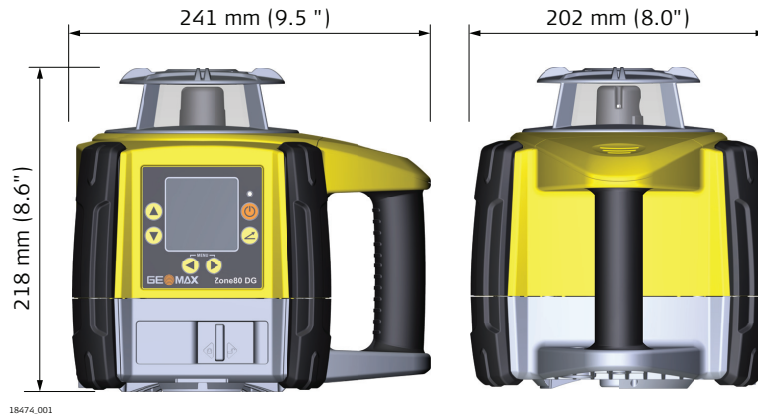

Grade Capability

± 10% in both axes simultaneously, 15% in one axis with up to 3% in the cross axis

Weight

Zone80 DG weight with battery: 3.4 kg/7.4 lbs.

Internal battery

Type	Operating times* at 20 °C
Lithium-Ion (Li-Ion pack)	40 h

*Operating times are dependent upon environmental conditions.

 Charging the Li-Ion battery pack takes a maximum of five hours.

Environmental specifications

Temperature

Operating temperature	Storage temperature
-20 °C to +50 °C (-4 °F to +122 °F)	-40 °C to +70 °C (-40 °F to +158 °F)

Protection against water, dust and sand

Protection
IP67
Dust tight
Waterproof to 1 m temporary immersion.

Lithium-Ion charger

Type	Value
Input voltage	100 V AC-240 V AC, 50 Hz-60 Hz
Output voltage	12 V DC
Output current	3.0 A
Polarity	Shaft: negative, Tip: positive

Lithium-Ion battery pack

Type	Value
Input voltage	12 V DC
Input current	2.5 A
Charge time	5 hours (maximum) at 20 °C

13.3.1

ZRC60 Remote Control

Operating range

Type	Value
Operating range (diameter)	300 m / 1000 ft

Batteries

Type	Value
Batteries	Alkaline, two AA-cells
Battery life, typical usage	70 hours

Remote control dimensions





SOLD &
SERVICED BY
**Survey
Instrument
Sales**

Helping You
Measure the World

24037 Acacia Redford, MI 48239
313-535-5252



879491-1.0.0en

Original text (879491-1.0.0en)
© 2019 GeoMax AG, Widnau, Switzerland



GeoMax AG
www.geomax-positioning.com